



# TargetAmp™ 2-Round Aminoallyl-aRNA Amplification Kit 1.0

**Cat. No. TAA2R5605 – 5 Reactions**

**Cat. No. TAA2R4910 – 10 Reactions**

**Cat. No. TAA2R4924 – 24 Reactions**

## **LIMITED LABEL LICENSE**

This product is covered by intellectual property licensed to EPICENTRE from Johnson & Johnson Pharmaceutical Research & Development, L.L.C.

This product is covered by U.S. Patents licensed exclusively to Incyte Corporation and sublicensed to EPICENTRE. The purchase of this product conveys to the buyer the limited, non-exclusive, non-transferable right (without the right to resell, repackage or further sublicense) under those patents to perform the RNA amplification methods claimed in those patents for research and development purposes, including clinical development of pharmaceutical and diagnostic products and services, solely in conjunction with this product. No other license is granted to the buyer whether expressly, by implication, by estoppel or otherwise. In particular, no rights are conveyed to the buyer to use the product or components of the product for purposes including but not limited to provision of services to a third party, generation of commercial databases or clinical diagnostics. This product is sold pursuant to authorization from Incyte Corporation and Incyte Corporation reserves all other rights under these patents. For information on purchasing a license to the patents of Incyte Corporation for uses other than in conjunction with this product or to use this product for purposes other than research, please contact Incyte Corporation Licensing, Experimental Station, Building 336, Route 141 and Henry Clay Road, Wilmington, DE 19880. Phone 302-498-6700.

*-continued  
Lit. #237*

<b>Table of Contents</b>	<b>Page</b>
KIT CONTENTS	3
Storage	3
Additionally Required Reagents and Equipment	3
Performance Specifications and Quality Control	4
INTRODUCTION	4
Features and Benefits of the TargetAmp 2-Round Aminoallyl-aRNA Amplification Kit 1.0	4
Round-One, 1 <sup>st</sup> -strand cDNA Synthesis	4
Round-One, 2 <sup>nd</sup> -strand cDNA Synthesis	4
Round-One, <i>In Vitro</i> Transcription	4
Round-One, RNA Purification	4
Round-Two, 1 <sup>st</sup> -strand cDNA Synthesis	6
Round-Two, 2 <sup>nd</sup> -strand cDNA Synthesis	6
<i>In Vitro</i> Transcription of Aminoallyl-aRNA	6
Reference	6
PREPARATION	6
Assessing the Quality of the Total RNA	6-7
Maintaining an RNase-free Environment	8
Input Total RNA and Aminoallyl-aRNA Yield	8-9
Aminoallyl-aRNA Purification	9
Additional Suggestions	9
RNA AMPLIFICATION PROCEDURE	10
Round-One, 1 <sup>st</sup> -strand cDNA Synthesis	10-11
Round-One, 2 <sup>nd</sup> -strand cDNA Synthesis	11-12
Round-One, <i>In Vitro</i> Transcription	12
Round-One, RNA Purification	13
Round-Two, 1 <sup>st</sup> -strand cDNA Synthesis	14-15
Round-Two, 2 <sup>nd</sup> -strand cDNA Synthesis	15
<i>In Vitro</i> Transcription of Aminoallyl-aRNA	16
Aminoallyl-aRNA Purification	17
Quantifying the Concentration, Yield and Fold-Amplification of the Aminoallyl-aRNA	18
Assessing the Size of the Aminoallyl-aRNA Produced	19
APPENDIX 1	
The TargetAmp 2-Round Aminoallyl-aRNA Amplification Kit 1.0 Control Reaction	20
APPENDIX 2	
Labeling the Aminoallyl-aRNA with Biotin-NHS or Fluorescent Dye-NHS	20
ADDITIONAL TARGETAMP aRNA AMPLIFICATION KITS & SELECTION GUIDE	21
RELATED PRODUCTS	22

**KIT CONTENTS**

**Storage**

**Additionally Required Reagents and Equipment**

**Performance Specifications and Quality Control**

The kit components are supplied in tubes with colored caps for easier identification.

The kit has been developed for use with and will provide optimal results with **SuperScript™ III and SuperScript II Reverse Transcriptases** (Invitrogen Corp.; provided by the user).

Component Name	Tube Label	Reaction Size Kits		
		5	10	24
Red-Cap Tubes				
TargetAmp™ T7-Oligo(dT) Primer B	T7-Oligo(dT) Primer B	10 µl	15 µl	30 µl
TargetAmp™ Reverse Transcription PreMix-SS	RT PreMix-SS	25 µl	50 µl	90 µl
TargetAmp™ DNA Polymerase PreMix-SS 1	DNA Pol PreMix-SS 1	30 µl	60 µl	120 µl
TargetAmp™ DNA Polymerase-SS 1	DNA Polymerase-SS 1	10 µl	10 µl	18 µl
TargetAmp™ cDNA Finishing Solution-SS	Finishing Solution-SS	10 µl	15 µl	30 µl
Blue-Cap Tubes				
TargetAmp™ Random Primers-SS	Random Primers-SS	15 µl	30 µl	55 µl
TargetAmp™ RNase H-SS	RNase H-SS	10 µl	10 µl	18 µl
TargetAmp™ T7-Oligo(dT) Primer C	T7-Oligo(dT) Primer C	10 µl	15 µl	30 µl
TargetAmp™ DNA Polymerase PreMix-SS 2	DNA Pol PreMix-SS 2	75 µl	150 µl	360 µl
TargetAmp™ DNA Polymerase-SS 2	DNA Polymerase-SS 2	10 µl	10 µl	18 µl
Green-Cap Tubes				
TargetAmp™ <i>In Vitro</i> Transcription PreMix A	IVT PreMix A	150 µl	300 µl	725 µl
TargetAmp™ <i>In Vitro</i> Transcription PreMix B	IVT PreMix B	90 µl	180 µl	425 µl
TargetAmp™ T7 RNA Polymerase	T7 RNA Polymerase	50 µl	100 µl	225 µl
TargetAmp™ T7 Transcription Buffer	T7 Transcription Buffer	50 µl	100 µl	225 µl
Aminoallyl-UTP	Aminoallyl-UTP	15 µl	30 µl	65 µl
RNase-Free DNase I	DNase I	25 µl	50 µl	115 µl
Colorless-Cap Tubes				
Dithiothreitol (DTT)	DTT	60 µl	100 µl	250 µl
HeLa Total RNA Control (40 ng/µl)	HeLa Total RNA Control	10 µl	10 µl	10 µl
RNase-Free Water	RNase-Free Water	1 ml	2x1 ml	2x1 ml
Poly(I)	Poly(I)	20 µl	30 µl	30 µl

**Storage:** Upon receipt of this kit, remove the tube containing the **HeLa Total RNA Control** and store it at -70°C to -80°C. Store the remainder of the kit at -20°C.

**Additionally Required Reagents and Equipment:**

SuperScript III **and** SuperScript II Reverse Transcriptase (Invitrogen Corp.)

Thermocycler or water bath

Microcentrifuge

RNase-Free Water

RNeasy® MinElute® Cleanup Kit

or

RNeasy Mini Kit (Qiagen) (see "**Aminoallyl-aRNA Purification**" page 17 for details)

---

**Performance Specifications and Quality Control**

The TargetAmp 2-Round Aminoallyl-aRNA Amplification Kit 1.0 is function-tested in a control reaction. The kit must produce at least 20 µg of aminoallyl-aRNA from 200 pg of HeLa Total RNA Control, corresponding to a greater than 5,000,000-fold amplification of the Poly(A) RNA assuming that 2% of the HeLa Total RNA Control is Poly(A) RNA. A negative control reaction ("no-RNA" control) produces less than 2 µg of aminoallyl-aRNA.

**INTRODUCTION****Features and Benefits of the TargetAmp 2-Round Aminoallyl-aRNA Amplification Kit 1.0****Round-One, 1<sup>st</sup>-strand cDNA Synthesis****Round-One, 2<sup>nd</sup>-strand cDNA Synthesis****Round-One, *In Vitro* Transcription****Round-One, RNA Purification****Round-Two, 1<sup>st</sup>-strand cDNA Synthesis****Round-Two, 2<sup>nd</sup>-strand cDNA Synthesis*****In Vitro* Transcription of Aminoallyl-aRNA****Features and Benefits of the TargetAmp 2-Round Aminoallyl-aRNA Amplification Kit 1.0**

- 1) Greater than 5,000,000-fold amplification of the Poly(A) RNA contained in a total RNA sample.
- 2) Produce microgram amounts of aminoallyl-aRNA from as little as 10 pg of total cellular RNA.
- 3) Utilizes an improved "Eberwine" linear RNA amplification process.
- 4) Virtually eliminates template-independent reactions.
- 5) Reproducible amplification results.
- 6) No need to purify the cDNA transcription template prior to the *in vitro* transcription reactions.
- 7) Fast reaction times...2-rounds of amplification can be completed in 2 days with about 4 hours of hands-on time.
- 8) Easy to use...color-coded tubes and a simplified pipetting scheme reduce labor and the possibility of error.

The TargetAmp™ 2-Round Aminoallyl-aRNA Amplification Kit 1.0 utilizes an improved "Eberwine" procedure<sup>1</sup> for amplifying Poly(A) RNA from as little as 10 pg of total cellular RNA. The kit requires both SuperScript III *and* SuperScript II Reverse Transcriptases (Invitrogen; provided by the user). See Figure 1 (page 5).

1. **Round-One, 1<sup>st</sup>-strand cDNA Synthesis:** The Poly(A) RNA component of a total RNA sample is reverse transcribed into first strand cDNA. The reaction is primed from a T7-Oligo(dT) primer...a synthetic oligo(dT) primer containing a phage T7 RNA Polymerase promoter sequence at its 5'-end. Round-one, 1<sup>st</sup>-strand cDNA synthesis is catalyzed by SuperScript III Reverse Transcriptase (provided by the user) and performed at an elevated temperature to reduce RNA secondary structure.
2. **Round-One, 2<sup>nd</sup>-strand cDNA Synthesis:** The RNA component of the cDNA:RNA hybrid produced in Step 1 is digested into small RNA fragments by RNase H. The RNA fragments then prime 2<sup>nd</sup>-strand cDNA synthesis. The resulting product is a double-stranded cDNA containing a T7 transcription promoter in an orientation that that will generate anti-sense RNA (aRNA) during the subsequent *in vitro* transcription reaction.
3. **Round-One, *In Vitro* Transcription:** High yields of anti-sense RNA (aRNA) are produced in a rapid *in vitro* transcription reaction that utilizes the double-stranded cDNA produced in Step 2.
4. **Round-One, RNA Purification:** The aRNA produced in the first round amplification procedure (Steps 1-3) is purified by spin column chromatography (supplied by the user).

Figure 1. TargetAmp 2-Round Aminoallyl-aRNA Amplification Kit 1.0 Procedure.

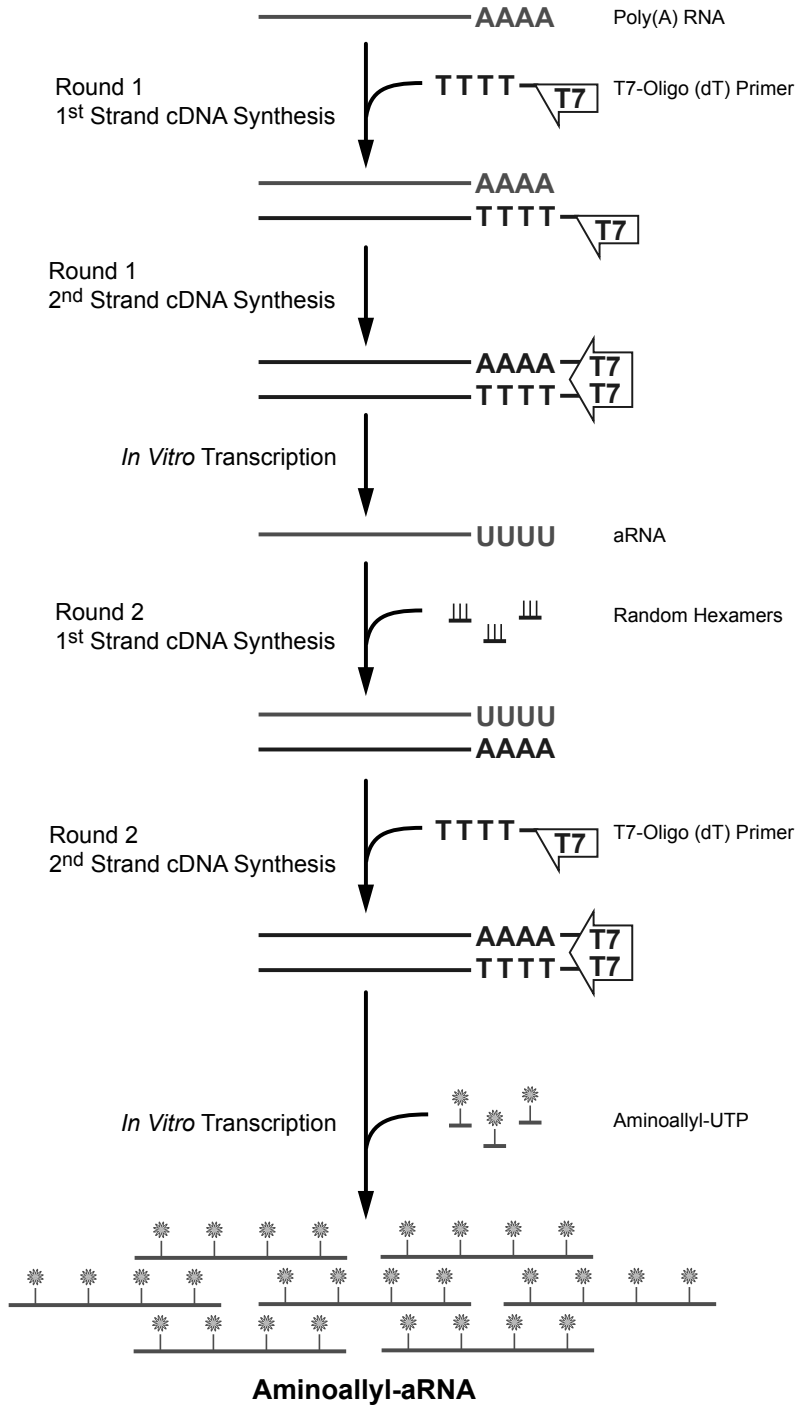

- 5. Round-Two, 1<sup>st</sup>-strand cDNA Synthesis:** The aRNA produced and purified in the first round amplification process is reverse transcribed into first strand cDNA using SuperScript II Reverse Transcriptase (Invitrogen; supplied by the user). The reaction is primed using random sequence hexamer primers.
- 6. Round-Two, 2<sup>nd</sup>-strand cDNA Synthesis:** The RNA component of the cDNA:aRNA hybrid produced in Step 5 is digested into small RNA fragments by RNase H. Second-strand cDNA synthesis is then primed using a T7-Oligo(dT) Primer. The resulting product is a double-stranded cDNA containing a T7 transcription promoter in an orientation that that will generate aRNA during the second round *in vitro* transcription reaction.
- 7. In Vitro Transcription of Aminoallyl-aRNA:** High yields of aminoallyl-aRNA are produced in an *in vitro* transcription reaction that utilizes the double-stranded cDNA produced in Step 6. In the transcription reaction, the canonical UTP nucleotide is partially substituted for with 5-(3-aminoallyl)-UTP (aminoallyl-UTP; AA-UTP).

A list of all the TargetAmp aRNA Amplification Kits as well as kits for RNA purification and aminoallyl-aRNA labeling are presented on pages 21-22.

#### **Reference:**

1. Van Gelder, R. N. *et al.*, (1990) *Proc. Natl. Acad. Sci. USA* **87** (5), 1663.

#### **PREPARATION**

**Assessing the Quality of the Total RNA**  
**Maintaining an RNase-free Environment**  
**Input Total RNA and Aminoallyl-aRNA Yield**  
**Aminoallyl-aRNA Purification**  
**Additional Suggestions**

#### **Assessing the Quality of the Total RNA:**

The success of microarray experiments is strongly influenced by the quality of the RNA. RNA quality has two components...purity of the RNA (or absence of contaminants) and integrity (intactness) of the RNA. RNA quality should be assessed prior to every RNA amplification reaction. **Poor quality RNA is the most common cause of sub-optimal RNA amplification results!**

**RNA Purification Methods and RNA Purity.** Total cellular RNA, isolated by a number of methods, can be amplified successfully using the TargetAmp 2-Round Aminoallyl-aRNA Amplification Kit. However, it is very important that the purified RNA be free of salts, metal ions, ethanol and phenol which can inhibit the enzymatic reactions performed in the RNA amplification process. Commonly used RNA extraction and purification methods that are compatible with the TargetAmp RNA amplification process include but are not limited to:

**TRIzol® / TRI Reagent®**, a homogeneous solution of the powerful denaturants guanidinium isothiocyanate and phenol, is very effective at extracting the RNA from the cells. However *all* traces of guanidinium salts and phenol must be removed from the RNA sample prior to the RNA amplification process. If you precipitate the RNA from TRIzol-extracted cells, be sure to wash the RNA pellet at least two times with cold 70-75% ethanol to remove all traces of phenol and guanidinium salts. *Air dry* the RNA pellet (do not use a vacuum centrifuge) to remove residual ethanol. Then, resuspend the RNA in RNase-Free water. If you purify the RNA from TRIzol-extracted cells by column purification methods, please read the section **“Spin Columns”** immediately following.

**Spin Columns** (e.g., the RNeasy MinElute Cleanup Kit and RNeasy Mini Kit from Qiagen) are effective in purifying RNA samples that are free of the contaminants that may inhibit the RNA amplification process. Spin columns can be used with most RNA extraction procedures (e.g. TRIzol reagent). If using spin columns, follow the manufacturer's instructions closely, especially if an ethanol wash of the RNA is performed prior to the RNA elution step. Then, elute the RNA from the column membrane using RNase-Free water. We recommend using spin columns to isolate RNA from tissue samples treated with RNA preservatives such as RNAlater® or RNAlater-ICE.

**Salt-Fractionation:** RNA purification that employs gentle salt-fractionation, such as EPICENTRE's ArrayPure™ Nano-scale RNA Purification Kit, routinely produce the highest yield of intact RNA without the use of phenol, guanidinium salts or columns. The ArrayPure kit has been developed for total RNA purification from 1-10,000 cells obtained by laser-capture methods such as Laser Capture Microdissection (LCM), from biopsy samples, from cell culture or quick-frozen tissue. To purify RNA from >10,000 cells, EPICENTRE's MasterPure™ RNA Purification Kit is recommended. When using these kits, be sure to wash the RNA pellet at least two times with cold 70-75% ethanol to remove all traces of salts. *Air dry* the RNA pellet (do not use a vacuum centrifuge) to remove residual ethanol. Then, resuspend the RNA in RNase-Free water. The ArrayPure kit and MasterPure kit are *not* recommended for purification of RNA from tissue samples preserved with RNAlater or RNAlater-ICE.

**RNA Integrity.** Successful microarray analysis using amplified RNA is dependent on an RNA sample that contains full-length, intact Poly(A) RNA. The most commonly used methods for assaying RNA integrity are by **denaturing agarose gel electrophoresis** or using an **Agilent 2100 Bioanalyzer**.

The advantages of **denaturing agarose gel electrophoresis** are its low cost and ready availability of the reagents required. Denaturing gel electrophoresis separates the RNAs by size (electrophoretic mobility) under denaturing conditions. Denaturing conditions are necessary to eliminate inter- and intra-molecular secondary structure within the RNA sample which may cause degraded RNA to appear intact. Following electrophoresis, the denaturing gel is stained with, for example, ethidium bromide and the user looks for the highly stained 18S and 28S rRNAs. These bands should be sharp and discrete with an absence of smearing under either. Based on these visual observations, the user infers that the mRNA in the sample is equally intact (or degraded). If the rRNA bands appear degraded, as evidenced by smearing under each, the RNA sample should be discarded and a new sample of total RNA purified. Ideally, the ethidium bromide stained 28S rRNA band should appear to be about twice as intense as the 18S rRNA band. The main disadvantage of denaturing gels is that they require a minimum of 1 µg of total RNA be loaded per lane...a quantity of RNA that often is not expendable for those performing RNA amplification.

The **Agilent 2100 Bioanalyzer** is currently the preferred method for evaluating the integrity of an RNA sample. Like a denaturing gel, the bioanalyzer separates the RNAs by size (electrophoretic mobility). However, in contrast to a denaturing gel, the 2100 Bioanalyzer consumes as little as 5 ng of total RNA per well when using the manufacturer's RNA 6000 Nano LabChip®. When analyzing the RNA sample using the Agilent 2100 Bioanalyzer, the 18S and 28S rRNA species should appear as distinct, sharp peaks on the electropherogram. A slightly increased baseline, indicative of the 1-5% Poly(A) RNA contained in the sample, can be seen between the two peaks.

**Maintaining an RNase-free Environment:**

Ribonuclease contamination is a significant concern for those performing RNA amplification. The ubiquitous RNase A is a highly stable and active ribonuclease that can contaminate any lab environment and is present on human skin. All components of the TargetAmp 2-Round Aminoallyl-aRNA Amplification Kit 1.0 have been tested to ensure the lack of contaminating ribonuclease activities. However, creating an RNase-free work environment and maintaining RNase-free solutions is critical for performing successful RNA amplification reactions. Therefore, we strongly recommend that the user:

- 1) Autoclave all tubes and pipette tips that will be used in the RNA amplification reactions.
- 2) Always wear gloves when handling samples containing RNA. Change gloves frequently especially after touching potential sources of RNase contamination such as door knobs, pens, pencils and human skin.
- 3) Always wear gloves when handling kit components. Do not pick up any kit component with an ungloved hand.
- 4) Keep all kit components tightly sealed when not in use. Keep all tubes containing RNA tightly sealed during the incubation steps.

**Input Total RNA and Aminoallyl-aRNA Yield:**

The TargetAmp 2-Round Aminoallyl-aRNA Amplification Kit 1.0 is extremely efficient at producing microgram amounts of aminoallyl-aRNA from picogram quantities of total RNA. The actual aminoallyl-aRNA yield and fold-amplification of Poly(A) RNA from a total RNA sample is dependent on:

- 1) The integrity (intactness) of the total RNA sample (discussed above).
- 2) The amount of total RNA used in the reaction.
- 3) The Poly(A) RNA content of the total RNA sample.

Typically, a total RNA sample from eukaryotic cells contains 1-5% Poly(A) RNA depending on the type of cell and its metabolic state. Table 1 shows the aminoallyl-aRNA yield and fold-amplification obtained from **high-integrity** total RNA from 3 different cell types, each containing a different percentage of Poly(A) RNA. **The information in Table 1 provides guidance to the amount of aminoallyl-aRNA that can be produced using exceptionally high-integrity total RNA of known Poly(A) RNA content and is not intended as a guarantee of yield.** If the Poly(A) RNA content of the sample is not known, a commonly used **assumption** is that Poly(A) RNA constitutes **2%** of a total RNA sample.

**Table 1. Yields of aminoallyl-aRNA (AA-aRNA) obtained from three total RNA sources, including the HeLa Total RNA Control provided in the kit, using the TargetAmp™ 2-Round Aminoallyl-aRNA Amplification Kit 1.0.** Results are the average of multiple experiments. The fold-amplification of the Poly(A) RNA in the total RNA sample is shown in parentheses.

<b>Amount of Total RNA Amplified</b>	<b>AA-aRNA yield from Total Rat Brain RNA</b> [assume 5% of rat brain total RNA is Poly(A) RNA]	<b>AA-aRNA yield from Total HeLa RNA</b> [assume 2% of HeLa total RNA is Poly(A) RNA]	<b>AA-aRNA yield from Total Rat Kidney RNA</b> [assume 1.5-2% of rat kidney total RNA is Poly(A) RNA]
<b>0 pg</b>	<b>0.6 µg</b>	<b>0.6 µg</b>	<b>0.6 µg</b>
<b>10 pg</b>	<b>3 µg (6 x10<sup>6</sup>)</b>	<b>1.3 µg (6.5 x10<sup>6</sup>)</b>	<b>1.4 µg (~9 x10<sup>6</sup>)</b>
<b>50 pg</b>	<b>19 µg (7.6 x10<sup>6</sup>)</b>	<b>8 µg (8 x10<sup>6</sup>)</b>	<b>7 µg (~9 x10<sup>6</sup>)</b>
<b>100 pg</b>	<b>53 µg (10.6 x10<sup>6</sup>)</b>	<b>19 µg (9.5 x10<sup>6</sup>)</b>	<b>15 µg (~10 x10<sup>6</sup>)</b>
<b>200 pg</b>	<b>103 µg (10.2 x10<sup>6</sup>)</b>	<b>34 µg (8.5 x10<sup>6</sup>)</b>	<b>31 µg (~10 x10<sup>6</sup>)</b>
<b>500 pg</b>	<b>161 µg (6.4 x10<sup>6</sup>)</b>	<b>71 µg (7.1 x10<sup>6</sup>)</b>	<b>72 µg (~9 x10<sup>6</sup>)</b>



**Important!** The TargetAmp 2-Round Aminoallyl-aRNA Amplification Kit has been optimized for producing >5,000,000-fold amplification of the Poly(A) RNA from 10-500 pg of total cellular RNA per reaction. Amplifying >500 pg of total RNA in a single TargetAmp 2-Round Amplification reaction may result in less than 5,000,000-fold amplification of the Poly(A) RNA and may result in under-representation of some Poly(A) RNA sequences in the aminoallyl-aRNA produced. Therefore, if it is desirable to perform an amplification reaction using >500 pg of total RNA, we strongly recommend that the user perform multiple reactions, each containing up to but not exceeding 500 pg of total RNA.

#### Aminoallyl-aRNA Purification:

The appropriate aminoallyl-aRNA (AA-aRNA) purification process (Step H, page 17) to use is dependent on the expected yield of AA-aRNA. Use the table on page 8 to estimate the yield of AA-aRNA from the amount of total RNA and the Poly(A) content of the total RNA used in each amplification reaction. If the Poly(A) RNA content of the sample is not known, assume it is 2% (comparable to the HeLa Total RNA Control). Then:

- 1) If the expected yield of AA-aRNA is <40 µg, purify the AA-aRNA using the **Qiagen MinElute Cleanup Kit**.
- 2) If the expected yield of AA-aRNA is >40 µg, purify the AA-aRNA using the **Qiagen RNeasy Mini Kit**.

#### Additional Suggestions:

##### Familiarize Yourself with the TargetAmp Kit and Procedure:

The TargetAmp 2-Round Aminoallyl-aRNA Amplification Kit 1.0 includes many reagents. Before starting, please read this protocol carefully and familiarize yourself with each kit component and in which step of the RNA amplification process it is used. Be sure to wear gloves when handling the kit components.

##### Importance of Running the TargetAmp 2-Round Aminoallyl-aRNA Control Reaction:

We strongly recommend that those who are not experienced with the TargetAmp 2-Round Aminoallyl-aRNA Amplification Kit perform a control amplification reaction (APPENDIX 1, page 20) prior to committing a precious sample. HeLa total RNA is provided with the kit as a control.

##### Performing the TargetAmp 2-Round Aminoallyl-aRNA Amplification Reactions:

We recommend that all reactions be performed in sterile 0.2 ml thin-walled tubes using sterile pipette tips and recently calibrated pipettors. Very small volumes of some kit components are required for each reaction. Therefore, we recommend the user prepare Master Mixes of reaction components when amplifying multiple samples.

##### Some Simple but Important Factors for Obtaining Optimal Results:

- 1) Familiarize yourself with the kit by running a control reaction (APPENDIX 1, page 20) before committing a precious sample.
- 2) Use up to but not more than 500 pg of total RNA per reaction.
- 3) Assemble the two *in vitro* transcription reactions (Step C and Step G) at room temperature. Do not exceed the *in vitro* transcription reaction times indicated in the procedure.
- 4) Use the appropriate RNA purification columns for purifying the aRNA and aminoallyl-aRNA produced.
- 5) Optional stopping points are noted following the 1<sup>st</sup>-round and 2<sup>nd</sup>-round 2<sup>nd</sup>-strand cDNA synthesis steps (Step B and Step F) and after purification of the aRNA (Step D) and aminoallyl-aRNA (Step H).

**RNA AMPLIFICATION PROCEDURE**

Round-One, 1<sup>st</sup>-strand cDNA Synthesis  
 Round-One, 2<sup>nd</sup>-strand cDNA Synthesis  
 Round-One, *In Vitro* Transcription  
 Round-One, RNA Purification  
 Round-Two, 1<sup>st</sup>-strand cDNA Synthesis  
 Round-Two, 2<sup>nd</sup>-strand cDNA Synthesis  
*In Vitro* Transcription of Aminoallyl-aRNA  
 Aminoallyl-aRNA Purification  
 Quantifying the Concentration, Yield and Fold-Amplification of the Aminoallyl-aRNA  
 Assessing the Size of the Aminoallyl-aRNA Produced

Please read through the TargetAmp 2-Round Aminoallyl-aRNA Amplification Kit 1.0 procedure carefully before beginning. We *strongly* recommend that those who are not experienced with the TargetAmp kit perform a control amplification reaction (APPENDIX 1, page 20) prior to committing a precious sample. A HeLa total RNA control is provided with the kit

**A. Round-One, 1<sup>st</sup>-strand cDNA Synthesis**

**SuperScript III Reverse Transcriptase** (Invitrogen) is required for use in this Step. The SuperScript III enzyme is provided by the user. The total RNA sample must be free of contaminating salts, metal ions, ethanol and phenol. For best results, the RNA sample should be dissolved in RNase-Free water.

Required in Step A

Component Name	Tube Label	Tube Color
TargetAmp™ T7-Oligo(dT) Primer B	T7-Oligo(dT) Primer B	Red
TargetAmp™ Reverse Transcription PreMix-SS	RT PreMix-SS	Red
Dithiothreitol	DTT	Colorless
RNase-Free Water	RNase-Free Water	Colorless
<b>Incubation temperatures performed in Step A: 50°C and 65°C.</b>		

**Important!** The TargetAmp 2-Round Aminoallyl-aRNA Amplification Kit has been optimized for producing >5,000,000-fold amplification of the Poly(A) RNA from 10-500 pg of total cellular RNA per reaction. Amplifying >500 pg of total RNA in a single TargetAmp 2-Round Amplification reaction may result in less than 5,000,000-fold amplification of the Poly(A) RNA and may result in under-representation of some Poly(A) RNA sequences in the aminoallyl-aRNA produced. Therefore, if it is desirable to perform an amplification reaction using >500 pg of total RNA, we *strongly* recommend that the user perform multiple reactions, each containing up to but not exceeding 500 pg of total RNA.

- Anneal the **TargetAmp T7-Oligo(dT) Primer B** to the RNA sample. If a “no template” control reaction is performed, substitute 2 µl of RNase-Free Water for the Total RNA sample.

**Important!** Be sure to use the **TargetAmp T7-Oligo(dT) Primer B** in this Step.

x µl RNase-Free Water  
 x µl Total RNA sample (10-500 pg)  
 1 µl TargetAmp T7-Oligo(dT) Primer B  

---

 3 µl Total

- Incubate at **65°C for 5 minutes** in a water bath or thermocycler.

3. Chill on ice for 1 minute. Centrifuge briefly in a microcentrifuge.
4. Prepare the **Round-One, 1<sup>st</sup>-Strand cDNA Synthesis Master Mix**.  
For **each** 1<sup>st</sup>-strand cDNA synthesis reaction, combine on ice:
  - 1.5 µl TargetAmp Reverse Transcription PreMix-SS
  - 0.25 µl DTT
  - 0.25 µl SuperScript III Reverse Transcriptase (200 U/µl)
  - 2 µl Total

**Important!** Be sure to use **SuperScript III Reverse Transcriptase**. Do not use the SuperScript 5X Buffer or the DTT that is provided with the enzyme.

5. Gently mix the **Round-One, 1<sup>st</sup>-Strand cDNA Synthesis Master Mix** and then add **2 µl** of it to each reaction.
6. Gently mix the reactions and then incubate each at **50°C for 30 minutes** in a water bath or thermocycler. If the thermocycler has a heated lid function, heat the lid only if the temperature of the lid can be maintained at about 50°C.

**B. Round-One, 2<sup>nd</sup>-strand cDNA Synthesis**

Required in Step B

Component Name	Tube Label	Tube Color
TargetAmp™ DNA Polymerase PreMix-SS 1	DNA Pol PreMix-SS 1	Red
TargetAmp™ DNA Polymerase-SS 1	DNA Polymerase-SS 1	Red
TargetAmp™ cDNA Finishing Solution-SS	Finishing Solution-SS	Red

**Incubation temperatures performed in Step B:** 37°C, 65°C and 80°C.

1. Prepare the **Round-One, 2<sup>nd</sup>-Strand cDNA Synthesis Master Mix**.  
For **each** 2<sup>nd</sup>-strand cDNA synthesis reaction, combine on ice:
  - 4.5 µl TargetAmp DNA Polymerase PreMix-SS 1
  - 0.5 µl TargetAmp DNA Polymerase-SS 1
  - 5 µl Total

**Important!** Be sure to use the **TargetAmp DNA Polymerase PreMix-SS 1** and the **TargetAmp DNA Polymerase-SS 1** in this reaction.

2. Gently mix the **Round-One, 2<sup>nd</sup>-Strand cDNA Synthesis Master Mix** and then add **5 µl** of it to each reaction.
3. Gently mix the reactions and then incubate at **65°C for 10 minutes** in a water bath or thermocycler. Centrifuge briefly in a microcentrifuge.

**Important!** Be sure to incubate the reactions at **65°C**.

4. Incubate the reactions at **80°C for 3 minutes**.  
Centrifuge briefly in a microcentrifuge then chill on ice.
5. Add **1 µl** of **TargetAmp cDNA Finishing Solution-SS** to each reaction.
6. Gently mix the reactions and then incubate at **37°C for 10 minutes**.

- Transfer the reactions to 80°C and then incubate the reactions at **80°C for 3 minutes**. Centrifuge briefly in a microcentrifuge then chill on ice.

**Note:** If desired, the reactions can now be frozen and stored overnight at -20°C.

**C. Round-One, *In Vitro* Transcription**

Required in Step C

Component Name	Tube Label	Tube Color
TargetAmp™ <i>In Vitro</i> Transcription PreMix A	IVT PreMix A	Green
TargetAmp™ T7 RNA Polymerase	T7 RNA Polymerase	Green
TargetAmp™ T7 Transcription Buffer	T7 Transcription Buffer	Green
Dithiothreitol	DTT	Colorless
RNase-Free DNase I	DNase I	Green

**Incubation temperatures performed in Step C:** 37°C and 42°C.

- Warm the **TargetAmp T7 RNA Polymerase** to room temperature. Thaw the remaining *in vitro* transcription reagents at room temperature. If a precipitate is visible in the thawed **TargetAmp T7 Transcription Buffer**, heat the Buffer to 37°C until it dissolves. **Keep the TargetAmp T7 Transcription Buffer at room temperature. Important!** Be sure to thaw and use the **TargetAmp *In Vitro* Transcription PreMix A** in this Step.
- Thoroughly mix the thawed **TargetAmp T7 Transcription Buffer**.

**Important!** If a precipitate is visible in the thawed TargetAmp T7 Transcription Buffer, heat the Buffer to 37°C until it dissolves. Mix the Buffer thoroughly. **Keep the Buffer at room temperature.**

- Prepare the **Round-One, *In Vitro* Transcription Master Mix**.  
For **each *in vitro* transcription reaction, combine at room temperature:**
  - 4 µl TargetAmp T7 Transcription Buffer
  - 27 µl TargetAmp *In Vitro* Transcription PreMix A
  - 4 µl DTT
  - 4 µl TargetAmp T7 RNA Polymerase
  - 39 µl Total
- Gently mix the **Round-One, *In Vitro* Transcription Master Mix** and then add **39 µl** of it to each reaction.
- Gently mix the reactions and then incubate at **42°C for 4 hours** in a thermocycler or a water bath. If the thermocycler has a heated lid function, heat the lid only if the temperature of the lid can be maintained at about 42°C.

**Important!** Do not exceed 4 hour incubation. The 4 hour incubation gives optimal RNA yield and quality (length). Longer incubation times will result in lower quality RNA.

- Add **2 µl of RNase-Free DNase I** to each reaction. Mix gently and then incubate each at **37°C for 15 minutes**.

**D. Round-One, RNA Purification**

This step uses the **Qiagen RNeasy MinElute Cleanup Kit** (Qiagen cat. no. 74204). Use the **RNase-Free Water** that is provided in the **MinElute Cleanup Kit**.

Required in Step D

Component Name	Tube Label	Tube Color
Poly(I)	Poly(I)	Colorless
<b>Note:</b> Use the RNase-Free Water provided in the RNeasy MinElute Cleanup Kit in this Step.		

1. Prepare 350 µl of **RLT/β-ME Solution** for each sample. Combine the RLT/β-ME in the ratio of 1 ml of Buffer RLT (provided in the MinElute kit) with 10 µl of β-ME (β-mercaptoethanol) as described in the MinElute kit handbook.
2. Prepare 650 µl of **RPE Solution** for each sample by diluting 1 volume of Buffer RPE (provided in the MinElute kit) with 4 volumes of 96-100% ethanol as described in the MinElute kit handbook.
3. To each sample add:
  - 47.5 µl RNase-Free Water
  - 0.5 µl Poly(I)
  - 350 µl RLT/β-ME Solution
  - 250 µl 100% Ethanol
4. Apply each sample to an **RNeasy MinElute spin column** in a 2 ml collection tube. Centrifuge at >8000 x g for 15 seconds. Discard the flow-through.
5. Apply 650 µl **RPE Solution** onto the column. Centrifuge at >8000 x g for 15 seconds. Discard the flow-through.
6. Apply 650 µl 80% ethanol onto the column. Centrifuge at >8000 x g for 15 seconds. Discard the flow-through.
7. Transfer the **RNeasy MinElute spin column** into a new collection tube. Centrifuge at full speed for 5 minutes.
8. Transfer the spin column to a 1.5 ml collection tube. Elute the aRNA by applying **14 µl of RNase-Free Water** directly onto the center of the silica-gel membrane. Wait for 5 minutes. Centrifuge at full speed for 1 minute.

**Note:** If desired, the RNA can now be quick frozen (e.g., dry ice/ethanol bath) and stored overnight at -80°C.

**E. Round-Two, 1<sup>st</sup>-strand cDNA Synthesis**

**SuperScript II Reverse Transcriptase** (Invitrogen) is required for use in this Step. The SuperScript II enzyme is provided by the user.

Required in Step E

Component Name	Tube Label	Tube Color
TargetAmp™ Reverse Transcription PreMix-SS	RT PreMix-SS	Red
TargetAmp™ Random Primers-SS	Random Primers-SS	Blue
TargetAmp™ RNase H-SS	RNase H-SS	Blue
<b>Incubation temperatures performed in Step E:</b> 37°C, 65°C and 95°C.		

- To each sample, add **2 µl** of the **TargetAmp Random Primers-SS**.
- Transfer the entire volume of the purified aRNA from Step E1 into a 0.2-0.6 ml sterile reaction tube in which the remainder of the amplification reactions will be performed.
- Adjust the volume of each aRNA sample to **3 µl** by speed vacuum centrifugation ***without heat***.  
**Important:** Do not allow the RNA samples to completely dry.

**Hint:** Two suggestions are presented for efficiently performing the speed vacuum concentration step:

Before concentrating the RNA sample, add 3 µl of water to a ***separate*** reaction tube. Mark the level of the 3 µl of water with a marking pen. Then, concentrate the RNA sample(s) using the speed vacuum centrifuge until it (they) is (are) at the same level in its (their) tube(s) as the 3 µl water sample.

Use water samples to determine the time necessary to reduce the RNA samples to 3 µl. For example, if there are 4 RNA samples to concentrate, add a volume of ***water*** equal to the volume of the RNA samples to each of 4 ***separate*** tubes. Speed vacuum centrifuge the ***water*** sample(s) to 3 µl final volume. Record the time needed to reduce the ***water*** samples volume to 3 µl. Then, concentrate the RNA sample(s) using the speed vacuum centrifuge for the same amount of time as needed to reduce the volume of the water sample(s) to 3 µl.

- Incubate at **65°C for 5 minutes** in a water bath or thermocycler.
- Chill on ice for 1 minute. Centrifuge briefly in a microcentrifuge.
- Prepare the **Round-Two, 1<sup>st</sup>-Strand cDNA Synthesis Master Mix**.  
For **each** 1<sup>st</sup>-strand cDNA synthesis reaction, combine on ice:
 

1.5 µl	TargetAmp Reverse Transcription PreMix-SS
0.25 µl	DTT
0.25 µl	SuperScript II Reverse Transcriptase (200 U/µl)
<hr style="width: 20%; margin-left: 0;"/>	
2 µl	Total

**Important!** Be sure to use **SuperScript II Reverse Transcriptase**. Do not use the SuperScript 5X Buffer or the DTT that is provided with the enzyme.

- Gently mix the **Round-Two, 1<sup>st</sup>-Strand cDNA Synthesis Master Mix** and then add **2 µl** of it to each reaction.
- Gently mix the reactions and then incubate each at **room temperature for 10 minutes**.

9. Transfer the reactions to 37°C and incubate each at **37°C for 1 hour** in a water bath or thermocycler. If the thermocycler has a heated lid function, heat the lid only if the temperature of the lid can be maintained at about 37°C.
10. To each sample, add **0.5 µl** of **TargetAmp RNase H-SS**.
11. Gently mix each reaction and then incubate each at **37°C for 20 minutes** in a water bath or thermocycler. If the thermocycler has a heated lid function, heat the lid only if the temperature of the lid can be maintained at about 37°C.
12. Transfer the reactions to 95°C.  
Incubate each at **95°C for 2 minutes** in a water bath or thermocycler.  
Chill on ice for 1 minute.  
Centrifuge briefly in a microcentrifuge.

**F. Round-Two, 2<sup>nd</sup>-strand cDNA Synthesis**

Required in Step F

Component Name	Tube Label	Tube Color
TargetAmp™ T7-Oligo(dT) Primer C	T7-Oligo(dT) Primer C	Blue
TargetAmp™ DNA Polymerase PreMix-SS 2	DNA Pol PreMix-SS 2	Blue
TargetAmp™ DNA Polymerase-SS 2	DNA Polymerase-SS 2	Blue

**Incubation temperatures performed in Step F:** 37°C, 42°C, 70°C and 80°C.

1. To each reaction add **1 µl** of the **TargetAmp T7-Oligo(dT) Primer C**.

**Important!** Be sure to use the **TargetAmp T7-Oligo(dT) Primer C** in this Step.

2. Gently mix the reactions and then incubate at **70°C for 5 minutes**, then incubate at **42°C for 10 minutes** in a water bath or thermocycler. Centrifuge briefly in a microcentrifuge.
3. Prepare the **Round-Two, 2<sup>nd</sup>-Strand cDNA Synthesis Master Mix**. For **each** 2<sup>nd</sup>-strand cDNA synthesis reaction, combine on ice:

13 µl TargetAmp DNA Polymerase PreMix-SS 2  
 0.5 µl TargetAmp DNA Polymerase-SS 2  
 13.5 µl Total

**Important!** Be sure to use the **TargetAmp DNA Polymerase PreMix-SS 2** and the **TargetAmp DNA Polymerase-SS 2** in this reaction.

4. Gently mix the **Round-Two, 2<sup>nd</sup>-Strand cDNA Synthesis Master Mix** and then add **13.5 µl** of it to each reaction.
5. Gently mix the reactions and then incubate at **37°C for 10 minutes** in a water bath or thermocycler. Centrifuge briefly in a microcentrifuge.
6. Incubate the reactions at **80°C for 3 minutes**. Centrifuge briefly in a microcentrifuge then chill on ice.

**Note:** If desired, the reactions can now be frozen and stored overnight at -20°C.

**G. *In Vitro* Transcription of Aminoallyl-aRNA**

Required in Step G

Component Name	Tube Label	Tube Color
TargetAmp™ <i>In Vitro</i> Transcription PreMix B	IVT PreMix B	Green
TargetAmp™ T7 RNA Polymerase	T7 RNA Polymerase	Green
TargetAmp™ T7 Transcription Buffer	T7 Transcription Buffer	Green
Aminoallyl-UTP	Aminoallyl-UTP	Green
Dithiothreitol	DTT	Colorless
RNase-Free Water	RNase-Free Water	Colorless
RNase-Free DNase I	DNase I	Green

**Incubation temperatures performed in Step G:** 37°C and 42°C.

1. Warm the **TargetAmp T7 RNA Polymerase** to room temperature. Thaw the remaining *in vitro* transcription reagents at room temperature. If a precipitate is visible in the thawed **TargetAmp T7 Transcription Buffer**, heat the Buffer to 37°C until it dissolves. Keep the TargetAmp T7 Transcription Buffer at room temperature.

**Important!** Be sure to thaw and use the **TargetAmp *In Vitro* Transcription PreMix B** in this Step.

2. Thoroughly mix the thawed **TargetAmp T7 Transcription Buffer**.

**Important!** If a precipitate is visible in the thawed TargetAmp T7 Transcription Buffer, heat the Buffer to 37°C until it dissolves. Mix the Buffer thoroughly. **Keep the Buffer at room temperature.**

3. Prepare the **Round-Two, *In Vitro* Transcription Master Mix**. For **each** *in vitro* transcription reaction, combine at room temperature:

9.6 µl RNase-Free Water  
 4 µl TargetAmp T7 Transcription Buffer  
 16 µl TargetAmp *In Vitro* Transcription PreMix B  
 2.4 µl Aminoallyl-UTP  
 4 µl DTT  
 4 µl TargetAmp T7 RNA Polymerase  

---

 40 µl Total

4. Gently mix the **Round-Two, *In Vitro* Transcription Master Mix** and then add **40 µl** of it to each reaction.
5. Gently mix the reactions and then incubate at **42°C for 9 hours** in a thermocycler. If the thermocycler has a heated lid function, heat the lid only if the temperature of the lid can be maintained at about 42°C. If the lid temperature can not be maintained at about 42°C, then perform the incubations without heating the lid. If an overnight reaction is planned, program the thermocycler to hold the samples at +4°C after the 9 hour incubation is complete.

**Important!** Do not exceed 9 hour incubation at 42°C. Optimal yield and quality (length) of aminoallyl-aRNA is achieved in 9 hours.

6. Add **2 µl of RNase-Free DNase I** to each reaction. Mix gently and then incubate each at **37°C for 15 minutes**.



## H. Aminoallyl-aRNA Purification

The purification column to use is dependent upon the expected yield of aminoallyl-aRNA (AA-aRNA). Use the table on page 8 to estimate the yield of AA-aRNA from the amount of total RNA and the Poly(A) content of the total RNA used in each amplification reaction. If the Poly(A) RNA content of the sample is not known, assume it is 2% (comparable to the HeLa Total RNA Control). Then,

If the expected yield of AA-aRNA is **<40 µg**:  
purify the AA-aRNA using the **Qiagen RNeasy MinElute Cleanup Kit**. (Qiagen cat. no. 74204)

If the expected yield of AA-aRNA is **>40 µg**:  
purify the AA-aRNA using the **Qiagen RNeasy Mini Kit**. (Qiagen cat. no. 74014)

Use the **RNase-Free Water** that is provided in the **MinElute Cleanup Kit** or the **RNeasy Mini Kit**. The following procedure should be used with either the MinElute Cleanup Kit or the RNeasy Mini Kit.

1. Prepare 350 µl of **RLT/β-ME Solution** for each sample. Combine the RLT/β-ME in the ratio of 1 ml of Buffer RLT (provided in the RNeasy kit) with 10 µl of β-ME (β-mercaptoethanol) as described in the RNeasy kit's handbook.
2. Prepare 1.4 ml of **RPE Solution** for each sample by diluting 1 volume of Buffer RPE (provided in the RNeasy kit) with 4 volumes of 96-100% ethanol as described in the RNeasy kit's handbook.
3. To each sample add:
  - 38 µl RNase-Free Water
  - 350 µl RLT/β-ME Solution
  - 250 µl 100% Ethanol
4. Apply each sample to the RNeasy spin column in a 1.5 ml collection tube. Centrifuge at >8000 x g for 15 seconds. Discard the flow-through.
5. Apply 700 µl **RPE Solution** onto the column. Centrifuge at >8000 x g for 15 seconds. Discard the flow-through. Reattach the 1.5 ml collection tube to the column.
6. Apply **another** 700 µl **RPE Solution** onto the column. Centrifuge at >8000 x g for 2 minutes. Discard the flow-through. Reattach the 1.5 ml collection tube to the column.
7. Centrifuge at full speed for 1 minute. Discard the flow-through.
8. Transfer the RNeasy spin column to a new 1.5 ml collection tube. Apply at least 25 µl of RNase-Free Water directly to the column. Wait for 5 minutes at room temperature.
9. Centrifuge at >8000 x g for 1 minute to collect the aminoallyl-aRNA.

**Note:** If desired, the reactions can now be quick frozen (e.g., dry ice/ethanol bath) and stored overnight at -80°C.

## I. Quantifying the Concentration, Yield and Fold-Amplification of the Aminoallyl-aRNA

**Concentration and yield:** The concentration of the aminoallyl-aRNA can be readily determined using a NanoDrop® ND-1000 UV-Vis Spectrophotometer available from NanoDrop Technologies. Alternatively, due to the high yield of aminoallyl-aRNA (AA-aRNA) that is produced by a TargetAmp reaction, the yield and concentration of AA-aRNA can be determined by standard UV spectroscopy.

1. Prepare a dilution of the AA-aRNA into the minimum volume of water or TE Buffer (10 mM Tris-HCl [pH 7.5], 1 mM EDTA) required by the spectrophotometer cuvette that will be used.
2. Zero the spectrophotometer at 260 nm using the diluents (water or TE buffer) that was used to dilute the AA-aRNA sample.
3. Measure and record the absorbance of the diluted AA-aRNA at 260 nm ( $A_{260}$ ).
4. Calculate the concentration of the AA-aRNA. Use the conversion factor that an  $A_{260}$  reading of 1.0 is equal to an RNA concentration of 40  $\mu\text{g/ml}$ .

**AA-aRNA concentration = ( $A_{260}$  reading) x (dilution factor) x (40  $\mu\text{g/ml}$ ).**

Example: Dilution for  $A_{260}$  measurement = 1:100 with an  $A_{260}$  of the 1:100 dilution = 0.15.

AA-aRNA concentration =  $(0.15) \times (100) \times (40 \mu\text{g/ml}) = 600 \mu\text{g/ml} = (0.6 \mu\text{g}/\mu\text{l})$  AA-aRNA.

5. Calculate the yield of AA-aRNA using the formula:

**Yield of AA-aRNA = (AA-aRNA Concentration) x (Volume of AA-aRNA).**

Example: 50  $\mu\text{l}$  of AA-aRNA recovered from column, 0.6  $\mu\text{g}/\mu\text{l}$  AA-aRNA determined in Step I4.

AA-aRNA yield =  $(0.6 \mu\text{g}/\mu\text{l}) \times (50 \mu\text{l}) = 30 \mu\text{g}$  of AA-aRNA.

In this example, 1  $\mu\text{l}$  of 0.6  $\mu\text{g}/\mu\text{l}$  of AA-aRNA was used for the spectrophotometer reading so there are now 29.4  $\mu\text{g}$  of AA-aRNA remaining.

**Fold amplification:** The fold-amplification of the reaction can be calculated once the yield of the AA-aRNA has been determined. However, if the input RNA was **total RNA**, an accurate calculation of fold-amplification requires knowledge of the Poly(A) content of the original total RNA sample. If the Poly(A) content of the sample is not known, a commonly used assumption is that Poly(A) RNA constitutes **2%** of the RNA in a total RNA sample.

**Fold-amplification = (amount of AA-aRNA produced) / ([amount of total RNA input] x [Percentage of Poly(A) RNA in the total RNA sample]).**

Example: Amount of input total RNA = 200 pg, Percentage of Poly(A) RNA in the sample (assumed) = 2% (0.02), Amount of AA-aRNA produced = 30,000,000 pg (30  $\mu\text{g}$ ).

Fold-amplification =  $30,000,000 \text{ pg} / (200 \text{ pg} \times 0.02) = 7,500,000$ .

**J. Assessing the Size of the Aminoallyl-aRNA Produced**

A TargetAmp 2-Round Aminoallyl-aRNA Amplification Kit 1.0 reaction typically produces aminoallyl-aRNA with a size distribution between 300-3000 bases with an average size of about 600 bases.

**Sizing the aminoallyl-aRNA by denaturing gel electrophoresis:** The advantages of denaturing agarose gel electrophoresis are its relatively low cost and ready availability of the reagents required. When assessing the size distribution of the aminoallyl-aRNA, load at least 1  $\mu$ g into the well of a 1% formaldehyde-agarose gel. Load RNA size markers that cover the size range of approximately 100-2000 bases.

**Sizing the aminoallyl-aRNA using the Agilent 2100 Bioanalyzer:** Dilute an aliquot of the aminoallyl-aRNA with water to approximately 100 ng/ $\mu$ l. Using the Agilent RNA 6000 Nano LabChip, load 1  $\mu$ l of the diluted aminoallyl-aRNA per well. It is advisable to load and run duplicates of each sample tested. If a control reaction containing no input RNA was performed, load 1  $\mu$ l of this sample as well. Run the samples per instrument procedure.

**APPENDIX 1 The TargetAmp 2-Round Aminoallyl-aRNA Amplification Kit 1.0 Control Reaction**

The TargetAmp kit provides 400 ng of total human HeLa RNA at a concentration of 40 ng/μl.

Required for the TargetAmp Control Reaction

Component Name	Tube Label	Tube Color
HeLa Total RNA Control (40 ng/μl)	HeLa Total RNA	Colorless
TargetAmp™ T7-Oligo(dT) Primer B	T7-Oligo(dT) Primer B	Red
RNase-Free Water	RNase-Free Water	Colorless

1. Thaw the **HeLa Total RNA Control** on ice.
2. On ice, dilute the thawed HeLa Total RNA Control 1:200 with RNase-Free Water by adding 1 μl of the HeLa Total RNA Control to 199 μl of RNase-Free Water. The concentration of the diluted RNA Control is 200 pg/μl.
3. Anneal the **TargetAmp T7-Oligo(dT) Primer B** to the **HeLa Total RNA Control**. The standard control reaction utilizes 200 pg of the HeLa Total RNA Control.  
**Important!** Be sure to use the **TargetAmp T7-Oligo(dT) Primer B** in this Step.
  - 1 μl RNase-Free Water
  - 1 μl HeLa Total RNA Control (200 pg)
  - 1 μl TargetAmp T7-Oligo(dT) Primer B
  - 3 μl Total
4. Incubate the reaction at **65°C for 5 minutes** in a water bath or thermocycler. While the reaction incubates, quick-freeze the HeLa Total RNA Control (40 ng/μl; for example in a dry ice/ethanol bath) and return it to -70°C to -80°C storage. Discard the diluted RNA Control.
5. Cool the annealing reaction on ice for at least 1 minute. Centrifuge the tube for 5-10 seconds to bring the sample to the bottom of the tube.
6. Continue the Control Reaction as described beginning in Step A4 on page 11.

**APPENDIX 2 Labeling the Aminoallyl-aRNA with Biotin-NHS or Fluorescent Dye-NHS**

The aminoallyl-aRNA produced using the kit can be readily labeled with amine-reactive N-hydroxysuccinimide (NHS) ester of Biotin (e.g., Biotin-X-X-NHS) or fluorescent dyes (e.g., Cy<sup>®</sup>3-NHS or Cy<sup>®</sup>5-NHS; GE Healthcare). In aqueous solution, the -NHS group of the biotin or fluorescent dye rapidly and with high efficiency reacts with the amine groups of the aminoallyl-uridine that was incorporated into the aminoallyl-aRNA during the *in vitro* transcription reaction. The end product is RNA with covalently attached biotin or fluorescent label.

Biotin-X-X-NHS is now available from EPICENTRE in convenient 2.5 mg packages (see page 22). The Biotin-X-X-NHS is provided in a septum-sealed vial to prevent moisture from entering the vial. A complete protocol for conjugating the Biotin-X-X-NHS to aminoallyl-aRNA is provided with the product.

**ADDITIONAL TARGETAMP aRNA AMPLIFICATION KITS & SELECTION GUIDE**

**TargetAmp™ 1-Round Aminoallyl-aRNA Amplification Kit 101**

TAA1R5605.....5 Reactions      TAA1R4910..... 10 Reactions      TAA1R4924.....24 Reactions

This kit will amplify Poly(A) RNA by **>5,000 fold** from as little as **25 ng** of total cellular RNA. The kit produces aminoallyl-aRNA and is optimized for use of SuperScript III Reverse Transcriptase (provided by the user).

**TargetAmp™ 1-Round Aminoallyl-aRNA Amplification Kit 102**

TAA1R5110M.....10 Reactions      TAA1R5124M..... 24 Reactions

This kit will amplify Poly(A) RNA by **>6,000 fold** and will produce microgram amounts of aminoallyl-aRNA from as little as **25 ng** of total RNA. The kit is optimized for use with EPICENTRE's MonsterScript™ Reverse Transcriptase (sold separately).

**TargetAmp™ 1-Round aRNA Amplification Kit 103**

TAU1R5705.....5 Reactions      TAU1R5110..... 10 Reactions      TAU1R5124.....24 Reactions

This kit will amplify Poly(A) RNA by **>5,000 fold** producing microgram amounts of unlabeled aRNA from as little as **25 ng** of total cellular RNA. The kit is optimized for use with SuperScript III Reverse Transcriptase (provided by the user).

**TargetAmp™ 2-Round aRNA Amplification Kit 2.0**

TAU2R5110.....10 Reactions

This kit will amplify Poly(A) RNA by **>5,000,000 fold** producing microgram amounts of unlabeled aRNA from as little as **10 pg** of total cellular RNA. The kit is optimized for use with SuperScript III and SuperScript II Reverse Transcriptases (provided by the user).

	TargetAmp™ 1-Round Aminoallyl-aRNA Amplification Kit 101	TargetAmp™ 1-Round Aminoallyl-aRNA Amplification Kit 102	TargetAmp™ 1-Round aRNA Amplification Kit 103	TargetAmp™ 2-Round aRNA Amplification Kit 2.0
Starting Total RNA	25-500 ng	25-500 ng	25-500 ng	10-500 pg
Reverse Transcriptase(s) Used	SuperScript™ III (provided by the user)	MonsterScript™ (provided by the user)	SuperScript™ III (provided by the user)	SuperScript™ III & SuperScript™ II (provided by the user)
Fold Amplification	>5000	>6,000	>5000	>5,000,000
Time Required	1 Day	1 Day	1 Day	2 Days
End Product	Aminoallyl-aRNA	Aminoallyl-aRNA	aRNA	aRNA

---

**RELATED PRODUCTS****Reverse Transcriptase****MonsterScript™ Reverse Transcriptase**

MSTA5110 .....10 Reactions      MSTA5124..... 24 Reactions

MonsterScript Reverse Transcriptase is a thermostable reverse transcriptase that completely lacks RNase H activity. The enzyme is highly efficient at producing full-length cDNA from RNA templates up to or greater than 15 kb.

**Kits for Isolating Total Cellular RNA and mRNA****ArrayPure™ Nano-scale RNA Purification Kit**

MPS04050 .....50 Purifications

The ArrayPure Kit provides all reagents needed to purify total RNA from 1-10,000 eukaryotic cells without the use of organic solvents such as phenol or columns.

**MasterPure™ RNA Purification Kit**

MCR85102 .....100 Purifications

The MasterPure RNA Purification Kit provides all reagents needed to purify total RNA from >10,000 eukaryotic cells without the use of organic solvents such as phenol or columns.

**mRNA-ONLY™ Eukaryotic mRNA Isolation Kit**

MOE51010.....10 Purifications      MOE51024 ..... 24 Purifications

The mRNA-Only Eukaryotic mRNA Isolation Kit provides simple and effective isolation of eukaryotic mRNA that is substantially free of ribosomal RNA in 1 hour. The kit does not use oligo(dT), columns or resins.

**mRNA-ONLY™ Prokaryotic mRNA Isolation Kit**

MOP51010.....10 Purifications      MOP51024 ..... 24 Purifications

The mRNA-Only Prokaryotic mRNA Isolation Kit provides simple and effective isolation of prokaryotic mRNA that is substantially free of ribosomal RNA in 1 hour.

**Aminoallyl-aRNA Labeling Reagents****Biotin-X-X-NHS**

BXX51005.....5 x 2.5 mg vials      BXX51010..... 10 x 2.5 mg vials

Biotin-X-X-NHS can be used to rapidly and cost-effectively label aminoallyl-aRNA and aminoallyl-DNA with biotin for use in DNA microarrays or other biotin-probe applications.

**Aminoallyl-UTP**

AAU5202.....2.5 μmoles @ 50 mM

Aminoallyl-UTP is supplied in a convenient 50 mM solution.

*TargetAmp*, *ArrayPure*, *MasterPure*, *MonsterScript* and *mRNA-ONLY* are trademarks of EPICENTRE, Madison, Wisconsin.

*SuperScript* is a trademark of Invitrogen Corp., Carlsbad, California.

*MinElute* and *RNeasy* are registered trademarks of Qiagen Inc., Valencia, California.

*Cy* is a registered trademark of Amersham Pharmacia Biotech UK Ltd. Corp., Buckinghamshire, England.

*TRIZol* and *TRI Reagent* are registered trademarks of Molecular Research Center Inc., Cincinnati, Ohio.

*RNAlater* is a registered trademark of Ambion Inc., Austin, Texas.

*LabChip* is a registered trademark of Caliper Technologies Corp., Hopkinton, Massachusetts.

*NanoDrop* is a registered trademark of NanoDrop Technologies Inc., Wilmington, Delaware.