

## 580.439/639 Homework 7 Solutions

### Problem 1

**Part a)** For the cylinder model:

$$q = \sqrt{1 + s\tau_m} \quad L = \frac{\Delta x}{\lambda} = \frac{\Delta x}{\sqrt{\frac{a}{2G_m R_i}}} \quad G_\infty = \frac{1}{r_i \lambda} = \pi a^{3/2} \sqrt{\frac{2G_m}{R_i}}$$

where  $s$  is the Laplace transform variable in units of Hz. In class,  $s$  was dimensionless, because the transform was done in terms of  $T=t/\tau_m$  as the time variable. If  $t$  had been used, then the result would have been as above. Using  $t$  instead of  $T$  is appropriate here, because  $t$  will be used for the compartmental model. For that model:

$$r_{ij} = \frac{R_i \Delta x}{\pi a^2} \quad g_{mj} = G_m 2\pi a \Delta x \quad c_{mj} = C_m 2\pi a \Delta x$$

**Part b)** In class, it was shown that the cylinder model gives the following:

$$\begin{aligned} \begin{bmatrix} V_0 \\ I_0 \end{bmatrix} &= \begin{bmatrix} \cosh(qL) & \sinh(qL)/G_\infty q \\ G_\infty q \sinh(qL) & \cosh(qL) \end{bmatrix} \begin{bmatrix} V_1 \\ I_1 \end{bmatrix} \\ &= \begin{bmatrix} \cosh(\sqrt{1+s\tau_m} L) & \sinh(\sqrt{1+s\tau_m} L)/G_\infty \sqrt{1+s\tau_m} \\ G_\infty \sqrt{1+s\tau_m} \sinh(\sqrt{1+s\tau_m} L) & \cosh(\sqrt{1+s\tau_m} L) \end{bmatrix} \begin{bmatrix} V_1 \\ I_1 \end{bmatrix} \end{aligned}$$

For the compartmental model, mesh equations can be written as follows:

$$\begin{aligned} V_0 &= I_0 \frac{r_{ij}}{2} + (I_0 - I_1) z_{mj} \\ V_1 &= (I_0 - I_1) z_{mj} - I_1 \frac{r_{ij}}{2} \end{aligned}$$

where  $z_{mj}$  is the parallel combination of  $g_{mj}$  and  $c_{mj}$ :  $z_{mj} = 1/(g_{mj} + s c_{mj}) = 1/g_{mj}(1 + s\tau_m)$ . Again,  $s$  is the Laplace transform variable in units of Hz. After some algebra, these can be rearranged in the following form:

$$\begin{bmatrix} V_0 \\ I_0 \end{bmatrix} = \begin{bmatrix} 1 + \frac{r_{ij} g_{mj}}{2} (1 + s\tau_m) & r_{ij} + \frac{r_{ij}^2}{4} g_{mj} (1 + s\tau_m) \\ g_{mj} (1 + s\tau_m) & 1 + \frac{r_{ij} g_{mj}}{2} (1 + s\tau_m) \end{bmatrix} \begin{bmatrix} V_1 \\ I_1 \end{bmatrix} \quad (\dagger)$$

Note that the time constant  $\tau_m$  is the same in the two models. To see this, note that  $\tau_m = C_m / G_m$  in the cylinder model and  $\tau_m = c_{mj} / g_{mj} = C_m 2\pi a \Delta x / (G_m 2\pi a \Delta x) = C_m / G_m$  in the compartmental model.

**Part c)** The Taylor series approximations for cosh() and sinh() are

$$\cosh(u) = 1 + \frac{u^2}{2!} + \frac{u^4}{4!} + \dots$$

$$\sinh(u) = u + \frac{u^3}{3!} + \frac{u^5}{5!} + \dots$$

Substituting the Taylor series for cosh() and sinh() in the cylinder model and keeping only the first two terms gives

$$\begin{bmatrix} V_0 \\ I_0 \end{bmatrix} \approx \begin{bmatrix} 1 + \frac{q^2 L^2}{2!} & \frac{1}{G_\infty q} (qL + \frac{q^3 L^3}{3!}) \\ G_\infty L q^2 (1 + \frac{q^2 L^2}{3!}) & 1 + \frac{q^2 L^2}{2!} \end{bmatrix} \begin{bmatrix} V_1 \\ I_1 \end{bmatrix} \quad (\dagger\dagger)$$

This approximation depends on the fact that  $|q^2 L^2| \ll 1$ , which is less restrictive than the assumption that  $|qL| \ll 1$ , stated in the problem set.

1) The terms on the diagonal are the same in (†) and (††) because

$$q^2 = 1 + s\tau_m \quad \text{and} \quad L^2 = \frac{\Delta x^2}{\lambda^2} = \frac{\Delta x^2}{\left(\frac{a}{2G_m R_i}\right)} = \frac{R_i \Delta x}{\pi a^2} 2\pi a G_m \Delta x = r_{ij} g_{mj}$$

2) The terms below the diagonal are also the same because

$$G_\infty L q^2 = \pi a^{3/2} \sqrt{\frac{2G_m}{R_i}} \frac{\Delta x}{\sqrt{\frac{a}{2G_m R_i}}} (1 + s\tau_m) = 2\pi a G_m \Delta x (1 + s\tau_m) = g_{mj} (1 + s\tau_m)$$

Notice that this captures only the first term in the approximation from the cylinder model. The second term can be neglected to the extent that  $|q^2 L^2| \ll 1$ , as above.

3) For the upper diagonal term, there are two terms in both the cylinder and compartmental models. Proceeding as above, it is straightforward to show that

$$\frac{L}{G_\infty} = r_{ij} \quad \text{and} \quad \frac{q^2 L^3}{G_\infty} = r_{ij}^2 g_{mj} (1 + s\tau_m)$$

That is, the first terms agree exactly, but the second terms have different multipliers, 1/4 for the compartmental model but 1/3! = 1/6 for the cylinder model. Fortunately the second term is small compared to the first since from Eqn. (††)

$$\frac{\text{second term}}{\text{first term}} = \frac{q^3 L^3 / 3!}{qL} = \frac{q^2 L^2}{3!} \ll 1$$

Thus satisfactory agreement between the two models can be expected as long as  $|qL|^2 \ll 1$ . Note that this corresponds to choosing  $\Delta x / \lambda$  to be small since

$$|qL|^2 = \left| (1 + s\tau_m) \left( \frac{\Delta x}{\lambda} \right)^2 \right| = \left( \frac{\Delta x}{\lambda} \right)^2 |1 + s\tau_m|$$

Thus at D.C. ( $s=0$ ), the condition corresponds to  $(\Delta x / \lambda)^2 \ll 1$  or  $\Delta x^2 \ll \lambda^2$ . In other words, the lengths of the cylinders corresponding to each compartment should be short compared to the length constant of the cylinder.

**Part d)** At frequencies above D.C., the term  $|1 + s\tau_m|$  increases. In the sinusoidal steady state at frequency  $\omega$ , the increase goes as  $(1 + \omega^2 \tau_m^2)^{1/2}$ . Thus to attain the condition  $|qL|^2 \ll 1$ ,  $\Delta x^2$  should be chosen to be small compared to  $\lambda^2 / (1 + \omega^2 \tau_m^2)$ . As a rule of thumb, dendritic trees are strongly lowpass and frequencies above  $1/\tau_m$  are unlikely to be important. Thus choosing  $\Delta x^2 \ll \lambda^2 / 2$  is likely to be sufficient.

## Problem 2

**Part a)** For a semi-infinite cable the membrane potential in the DC steady state is

$$V(\chi, T \rightarrow \infty) = V_0 e^{-\chi} = V_0 e^{-x/\lambda}$$

thus the *MET* from point 0 to  $\chi$  is

$$MET_{0\chi} = -\ln A_{0\chi} = -\ln \frac{V_0 e^{-\chi}}{V_0} = \chi = \frac{x}{\lambda}$$

which is the electrotonic distance as required.

**Part b)** The voltage gain  $A_{PR}$  can be written in terms of the transfer and input impedances as

$$A_{PR} = \frac{V_R}{V_P} = \frac{K_{PR} I_P}{K_{PP} I_P} = \frac{K_{PR}}{K_{PP}}$$

It was shown in class that  $K_{PR} = K_{RP}$ . Assume that  $K_{PP} > K_{RR}$  when  $P$  is further from the soma than  $R$  as in the figure in the problem set. Then

$$A_{PR} = \frac{K_{PR}}{K_{PP}} < \frac{K_{RP}}{K_{RR}} = A_{RP}$$

and so  $MET_{PR} > MET_{RP}$  as required. This means that potentials spread further away from the soma than they do toward the soma.

### Problem 3

**Part a)** As the synapse moves away from the soma, the dendritic branches are smaller in diameter. All other things being equal, that means a higher input impedance, so a given current will produce a larger EPSP. The situation is slightly more complex because synapses produce conductance changes. In class, the membrane potential change produced by a synapse was derived as

$$V = E \frac{g_{syn} / Y_{in}}{1 + g_{syn} / Y_{in}} \quad (*)$$

where  $g_{syn}$  is the synaptic conductance,  $Y_{in}$  is the input admittance of the dendritic branch, and  $E$  is the synaptic reversal potential. This equation is only strictly true in the D.C. steady state or for some condition in which  $g_{syn}$  is constant in time, in which case  $Y_{in}$  is a conductance. In this condition, as  $Y_{in}$  decreases (further out in the dendritic tree)  $V$  increases. Ultimately, when  $g_{syn} / Y_{in} \gg 1$ , saturation occurs and no further increases are observed.

**Part b)** This part will be done assuming  $q=1$ , i.e. D.C. steady state. The task is to compute  $Y_{in}$  at the branch points of the dendritic tree, where the synapses are located. Because the cell can be reduced to an equivalent cylinder, the input admittance  $Y_0$  (see the sketch in the problem set for the definition of  $Y_0$ ) can be computed as the parallel combination of the input admittances of two cylinders:

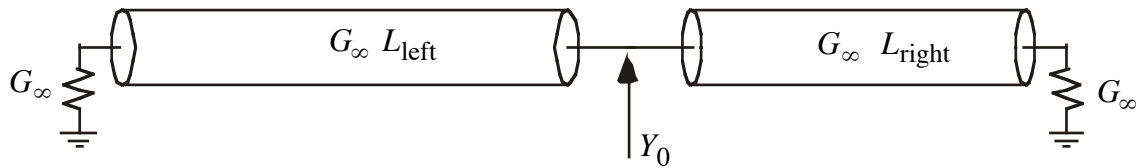

The cylinders are the equivalent cylinders for the part of the tree to the left of  $Y_0$  and for the part of the tree to the right of  $Y_0$ . Both cylinders have the  $G_\infty$  of the parent part of the original tree, terminated by conductance  $G_\infty$ , as shown (the sum of the terminating conductances at the  $2^n$  terminal branches). Using the input admittance rule defined in class,

$$Y_0 = G_\infty \frac{\frac{G_\infty}{G_\infty} + \tanh(L_{left})}{1 + \frac{G_\infty}{G_\infty} \tanh(L_{left})} + G_\infty \frac{\frac{G_\infty}{G_\infty} + \tanh(L_{right})}{1 + \frac{G_\infty}{G_\infty} \tanh(L_{right})} = 2G_\infty$$

At  $Y_1$ , the structure is slightly more complex:

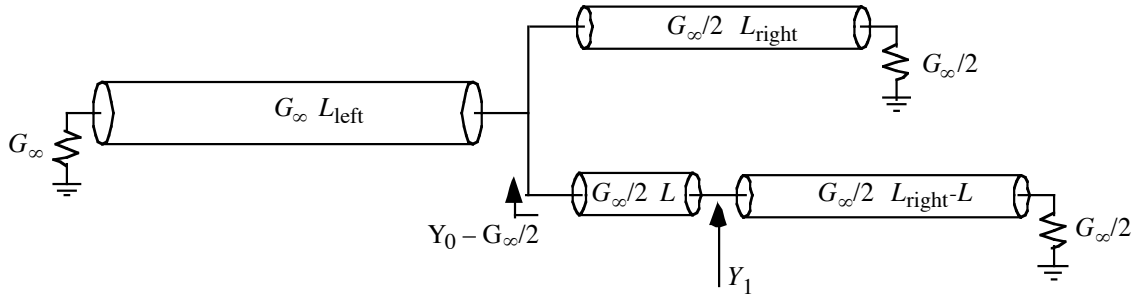

Now the right-hand cylinder has been broken into two parallel cylinders, with  $G_{\infty}/2$  and length  $L_{right}$ . The lower one has been split into the cylinder between  $Y_0$  and  $Y_1$  and the rest. Now  $Y_1$  is the sum of the input conductance of the  $L$ -length cylinder looking leftward and the remainder cylinder looking right (which is  $G_{\infty}/2$ ). This can also be expressed as  $Y_0 - G_{\infty}/2$ . Again using the conductance rule:

$$Y_1 = \frac{G_{\infty}}{2} \frac{\frac{Y_0 - G_{\infty}/2}{G_{\infty}/2} + \tanh(L)}{1 + \frac{Y_0 - G_{\infty}/2}{G_{\infty}/2} \tanh(L)} + \frac{G_{\infty}}{2} = \frac{G_{\infty}}{2} \frac{\frac{3G_{\infty}/2}{G_{\infty}/2} + \tanh(L)}{1 + \frac{3G_{\infty}/2}{G_{\infty}/2} \tanh(L)} + \frac{G_{\infty}}{2} = \frac{G_{\infty}}{2} \left[ \frac{3 + 0.2}{1 + 3 \cdot 0.2} + 1 \right]$$

$$= \frac{3G_{\infty}}{2}$$

where  $Y_0 - G_{\infty}/2$  is the load admittance seen by the length- $L$  cylinder at its left end, equal to the input admittance  $Y_0$  at that point, minus the contribution from the length- $L$  cylinder itself. Alternatively, this is  $G_{\infty}$  from the length- $L_{left}$  main cylinder plus  $G_{\infty}/2$  for the upper branch of the length  $L_{right}$  cylinder.

Proceeding similarly for  $Y_2$

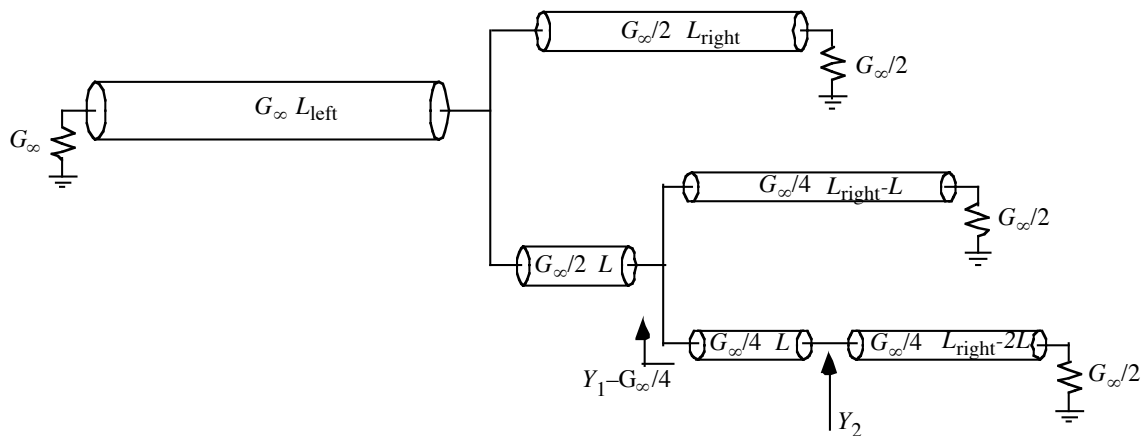

$$Y_2 = \frac{G_\infty}{4} \frac{\frac{Y_1 - G_\infty/4}{G_\infty/4} + \tanh(L)}{1 + \frac{Y_1 - G_\infty/4}{G_\infty/4} \tanh(L)} + \frac{G_\infty}{4} = \frac{G_\infty}{4} \frac{5 + 0.2}{1 + 5 \cdot 0.2} + \frac{G_\infty}{4}$$
$$= 0.9 \cdot G_\infty$$

This algorithm can be continued and generalized using induction. At the next branch point, for example,  $Y_3 = 0.48G_\infty$ .

So, at the first four branch points, the input conductances are 2, 1.5, 0.9, and 0.5 times  $G_\infty$ . Clearly  $K_i$  is increasing with branching, so the injection of fixed current will lead to larger EPSPs.

**Part c)** If the synapses are modeled correctly, as conductance changes, then Eqn. (\*) should be used. This equation is a monotonic function of  $g_{syn}/Y_{in}$ , so the same qualitative effect will be seen, but the saturation of Eqn. (\*) when  $g_{syn} > Y_{in}$  will limit the extent of the rise distally.