

580.439/639 Homework #6 Solutions

Problem 1

Part a) The derivation of the cable equation is the same up to the specification of the membrane impedance. That is, we can start from

$$\frac{1}{r_i+r_e} \frac{\partial^2 V}{\partial x^2} = i_m(x,t,V) = \text{membrane current/unit length of cylinder}$$

the membrane impedance is specified in the Laplace or Fourier domain, so this equation must be transformed. In this problem, the Fourier domain is more convenient, so

$$\frac{1}{r_i+r_e} \frac{\partial^2 \bar{V}}{\partial x^2} = \bar{i}_m(x,j\omega,V)$$

and

$$\bar{i}_m(x,j\omega,V) = \frac{1}{z_m} \bar{V}$$

where the bars indicate that the variables have been Fourier transformed. The variable ω in this case is radian frequency, because the differential equation has not been transformed to non-dimensional form. The resulting cable equation is then

$$\frac{1}{r_i+r_e} \frac{\partial^2 \bar{V}}{\partial x^2} \approx \frac{1}{r_i} \frac{\partial^2 \bar{V}}{\partial x^2} = \frac{1}{z_m} \bar{V} \quad \text{or} \quad \frac{z_m}{r_i} \frac{\partial^2 \bar{V}}{\partial x^2} - \bar{V} = 0 \quad (*)$$

Part b) The boundary conditions for this case are

$$\left. \frac{1}{r_i} \frac{\partial V}{\partial x} \right|_{x=0} = -I_0 \delta(t) \quad \text{and} \quad V(x \rightarrow \infty, t) = \text{finite}$$

The assumption of sinusoidal steady state is the equivalent of a boundary condition in time. Fourier transforming the spatial boundary condition at $x=0$ gives

$$\left. \frac{1}{r_i} \frac{\partial \bar{V}}{\partial x} \right|_{x=0} = -I_0$$

The solution to the differential equation (*) is

$$\bar{V}(x,j\omega) = A(j\omega) e^{\gamma x} + B(j\omega) e^{-\gamma x} \quad (**)$$

where

$$\gamma = \sqrt{\frac{r_i}{z_m}} \quad (***)$$

Note that γ is a complex number. For the purposes of evaluating the boundary conditions below, the positive-real root of Eqn. (***) is used for γ . The final solution is exactly the same if the negative-real root is chosen, except for the trivial difference that $B(j\omega)$ is zero, not $A(j\omega)$. By the

same argument that was given in class, the regularity condition as $x \rightarrow \infty$ implies that $A(j\omega) = 0$, so the solution (***) becomes

$$\bar{V}(x, j\omega) = B(j\omega) e^{-\gamma x}$$

and the boundary condition at 0 implies that

$$\frac{1}{r_i} \frac{\partial \bar{V}}{\partial x} \Big|_{x=0} = -\gamma \frac{B(j\omega)}{r_i} = -I_0 \quad \text{or} \quad B(j\omega) = \frac{r_i}{\gamma} I_0 \quad \text{so that} \quad \bar{V}(x, j\omega) = I_0 \frac{r_i}{\gamma} e^{-\gamma x}$$

Note that $r_i/\gamma = \sqrt{r_i z_m} = 1/Y_\infty$, by analogy with G_∞ .

Part c) Writing γ as $(g + jh)$ where $g = \text{Re}[\gamma]$ and $h = \text{Im}[\gamma]$, gives

$$\bar{V}(x, j\omega) = I_0 \frac{r_i}{g + jh} e^{-gx} e^{-jhx} \quad (****)$$

In keeping with the usual interpretation of the Fourier transform, Eqn. (****) is the complex magnitude of the potential at point x for a sinusoid at frequency ω . The component of the potential at frequency ω is obtained by multiplying by $e^{-j\omega t}$ and taking the real part

$$\begin{aligned} V(x, t) &= \text{Re} \left[I_0 \frac{r_i}{g + jh} e^{-gx} e^{-jhx} e^{-j\omega t} \right] \\ &= I_0 \frac{r_i}{\sqrt{g^2 + h^2}} e^{-gx} \cos(hx + \omega t - \phi) \end{aligned} \quad (*****)$$

where ϕ is the phase of the terms multiplying the exponentials, i.e. $-\arctan(h/g)$.

From Eqn. (*****) it is clear that the potential decays as e^{-gx} along the cylinder so that $1/g$ is the space constant at frequency ω . The potential oscillates along the cylinder with spatial frequency h .

Part d) For the special case of passive linear cable, $1/z_m = g_m + j\omega c_m$ and

$$\gamma = \sqrt{r_i(g_m + j\omega c_m)} = \sqrt{r_i g_m} \sqrt{1 + j\omega \frac{c_m}{g_m}} = \frac{1}{\lambda} \sqrt{1 + j\omega \tau_m}$$

Note that $\gamma = \sqrt{r_i g_m} = \lambda$ at D.C., so we haven't make any mistakes yet. Continuing,

$$\text{Re}[\gamma] = \frac{1}{\lambda} \text{Re}[\sqrt{1 + j\omega \tau_m}] = \frac{1}{\lambda} \text{Re}[(1 + \omega^2 \tau_m^2)^{0.25} \exp[j \arctan(\omega \tau_m)/2]]$$

where, once again, the positive-real root has been used. The A.C. space constant $1/\text{Re}[\gamma]$ can be written as

$$\frac{1}{\text{Re}[\gamma]} = \frac{\lambda}{\text{Re}[(1 + \omega^2 \tau_m^2)^{0.25} \exp[j \arctan(\omega \tau_m)/2]]} = \frac{\lambda}{[1 + \omega^2 \tau_m^2]^{0.25} \cos[\arctan(\omega \tau_m)/2]}$$

At low frequencies, $\omega \ll 1/\tau_m$, the A.C. space constant is approximately λ . At the cutoff frequency, where $\omega = 1/\tau_m$, the A.C. space constant is $\lambda/1.41 \cdot 0.92 = 0.77 \cdot \lambda$. As frequency increases, the A.C. space constant gets smaller in magnitude.

The important point here is that, as frequency increases, the space constant gets shorter and the cylinder gets electrotonically longer. Thus high frequency disturbances spread less. This is another way of saying that cylinders have a low-pass character.

Part e) The circuit at right shows the small-signal equivalent of a membrane with a leakage and delayed rectifier channel. The parameters were derived in a previous homework problem and are given in terms of Laplace transforms. For this circuit, $1/z_m$ is given by

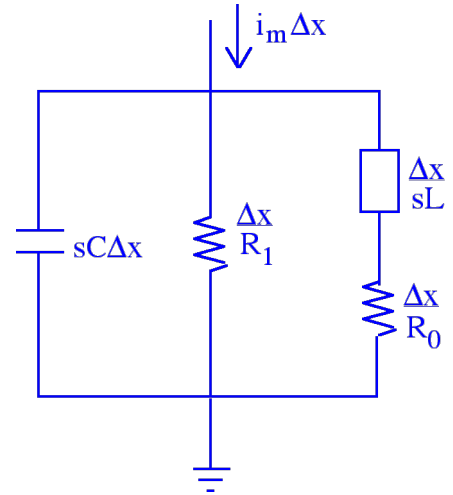

$$\frac{1}{z_m} = j\omega C + \frac{1}{R_1} + \frac{1}{R_0 + j\omega L} = \frac{-\omega^2 LC + j\omega \left[R_0 C + \frac{L}{R_1} \right] + 1 + \frac{R_0}{R_1}}{(R_0 + j\omega L)}$$

so the input conductance of the dendritic tree Y_∞ is given by

$$\begin{aligned} Y_\infty &= \frac{1}{\sqrt{r_i z_m}} = \sqrt{\frac{-\omega^2 LC + j\omega \left[R_0 C + \frac{L}{R_1} \right] + 1 + \frac{R_0}{R_1}}{r_i (R_0 + j\omega L)}} \\ &= \frac{1}{\sqrt{r_i r_p}} \sqrt{\frac{-\omega^2 LC \frac{r_p}{R_0} + j\omega \left[r_p C + \frac{L}{R_0 + R_1} \right] + 1}{1 + j\omega \frac{L}{R_0}}} \\ &= G_\infty \sqrt{\frac{-\omega^2 LC \frac{r_p}{R_0} + j\omega \left[r_p C + \frac{L}{R_0 + R_1} \right] + 1}{1 + j\omega \frac{L}{R_0}}} \end{aligned}$$

where $r_p = R_0$ in parallel with R_1 , i.e. $R_0 R_1 / (R_0 + R_1)$ and $G_\infty = 1/\sqrt{r_i r_p}$, by analogy with the usual definition. This is the square root of a second-order admittance. A second-order system can be resonant under appropriate circumstances, and if the system under the radical is resonant, then the radical will be resonant also, albeit with a smaller gain. For example, if the system has high Q (i.e. $1/j\omega_0 C \ll R_1$ and $j\omega_0 L \gg R_0$ then $R_1 \gg R_0$, $r_p \approx R_0$ and the resonant frequency is $\omega_0 \approx 1/\sqrt{LC}$.

Problem 2

Part a) If there are no external circuits carrying current out of or into the cell of interest, then the axial current inside the cell at a point x , $i_i(x)$, must be equal to the total extracellular current $i_e(x)$ flowing in the opposite direction at the same point, i.e.

$$i_i(x) = - i_e(x)$$

This equivalence follows from consideration of the cable structure below, where the rectangular boxes represent the internal, external, and membrane impedances.

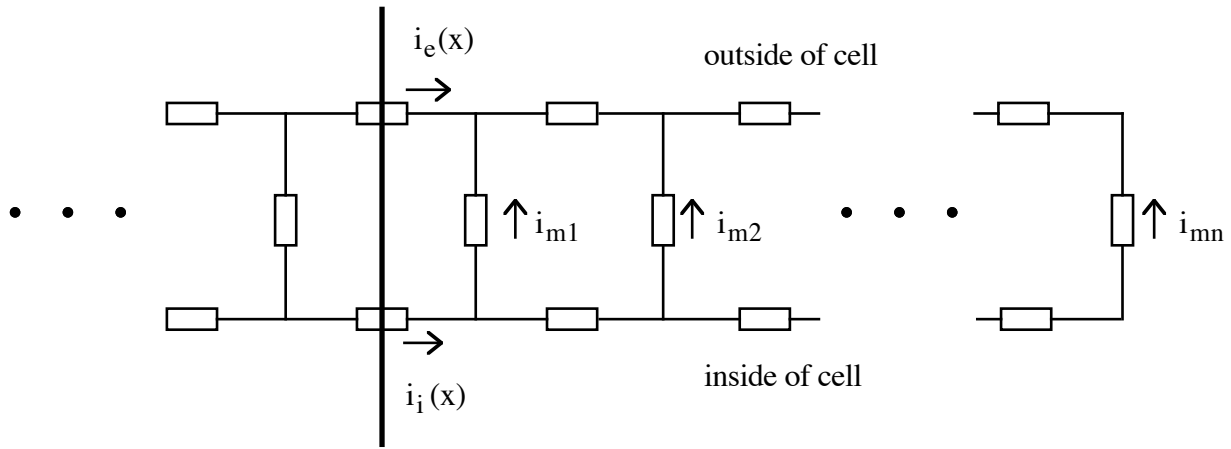

Successive application of Kirchoff's law to the nodes inside and then outside the cell will show that

$$i_i(x) = \sum_{j=1}^n i_{mj} = -i_e(x)$$

Substitution of the Ohm's law relationships used in deriving the cable equation gives

$$\frac{1}{r_i} \frac{\partial V_i}{\partial x} = -\frac{1}{r_e} \frac{\partial V_e}{\partial x}$$

subtracting $1/r_i \partial V_e / \partial x$ from both sides of the equations above give

$$\frac{1}{r_i} \frac{\partial V_i}{\partial x} - \frac{1}{r_i} \frac{\partial V_e}{\partial x} = -\frac{1}{r_e} \frac{\partial V_e}{\partial x} - \frac{1}{r_i} \frac{\partial V_e}{\partial x}$$

$$\frac{1}{r_i} \frac{\partial (V_i - V_e)}{\partial x} = -\left(\frac{1}{r_e} + \frac{1}{r_i}\right) \frac{\partial V_e}{\partial x}$$

rearranging and using the fact that transmembrane potential $V = (V_i - V_e)$ gives

$$\frac{\partial V_e}{\partial x} = -\frac{r_e}{r_e + r_i} \frac{\partial V}{\partial x} \tag{1.1}$$

Part b) Integrating equation 1.1 gives

$$\int_0^x \frac{\partial V_e}{\partial x} dx = -\frac{r_e}{r_e + r_i} \int_0^x \frac{\partial V}{\partial x} dx$$

carrying out the integrals and noting that $V(0) = 0$ due to the smash and that $V_e^*(x) = V_e(x) - V_e(0)$ by definition gives

$$V_e^*(x) = - \frac{r_e}{r_e + r_i} V(x)$$

Part c) In this case, all the cells are undergoing the same membrane potential events, so the potentials, both intracellular and extracellular, at any depth x should be the same near all the cells. As a result, potential V_e should vary only along the x axis and extracellular currents should also flow predominantly parallel to the x axis. The following equation, derived in class, relates the extracellular potential V_e to the cells' membrane currents $i_m(x)$.

$$\frac{\partial^2 V_e}{\partial x^2} = - r_e i_m$$

Using this equation, V_e can be computed by twice integrating the $i_m(x)$ data shown at left in the problem statement and multiplying by $-r_e$.