

## 580.439 Final Exam Solutions, 1997

### Problem 1

### Problem 2

**Part a)** The model is drawn at right, with the equilibrium potentials for the three ions shown as potentials on their batteries, computed using the Nernst equation. The resting potential for this circuit is the potential at which the net current through the membrane is zero, i.e.

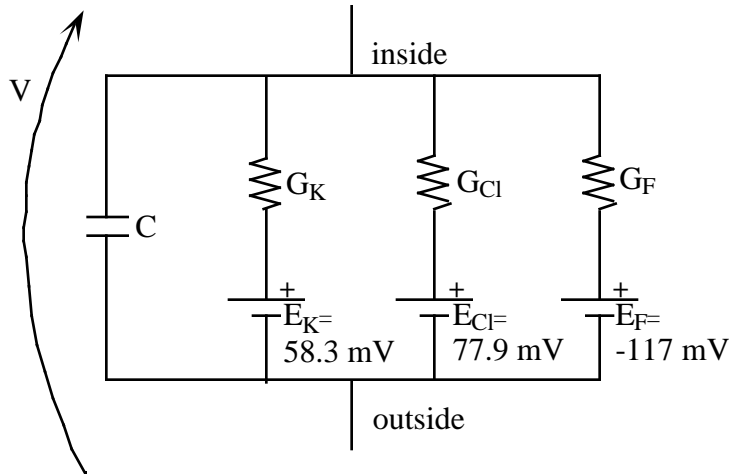

$$0 = G_K(V - E_K) + G_{Cl}(V - E_{Cl}) + G_F(V - E_F)$$

$$V_{rest} = \frac{G_K E_K + G_{Cl} E_{Cl} + G_F E_F}{G_K + G_{Cl} + G_F}$$

**Part b)** Changing the  $K^+$  concentration changes  $E_K$ , which changes  $V_{rest}$  unless  $G_K \ll G_{Cl}, G_F$ . This suggests that potassium can be ignored in determining the resting potential, i.e.

$$V_{rest} \frac{G_{Cl} E_{Cl} + G_F E_F}{G_{Cl} + G_F} = \frac{E_{Cl} + \frac{G_F}{G_{Cl}} E_F}{1 + \frac{G_F}{G_{Cl}}} \quad (1)$$

The conductance ratio  $G_F/G_{Cl}$  can be determined from Eqn. 1 by substituting for  $V_{rest}$ ,  $E_{Cl}$ , and  $E_F$ , giving

$$\frac{G_F}{G_{Cl}} = 0.11 \quad \text{and from the argument above} \quad \frac{G_K}{G_{Cl}} = 0$$

**Part c)** The membrane potential  $V$  can be made more negative by 1) increasing  $G_F$  or 2) decreasing  $G_{Cl}$  from their resting values. Changing  $G_K$  will not affect the membrane potential, since  $V_{rest} = E_K$ . Given that the total membrane conductance decreases, it must be the case that the change in membrane potential occurs due to a decrease in  $G_{Cl}$ . Using Eqn. 1 again, the conductance ratio  $G_F/G_{Cl}$  must increase to 1.24 when the membrane potential moves to -30 mV, assuming  $G_K/G_{Cl}$  remains near 0.

**Part d)** Apparently the virus causes production of a  $K^+$  channel so that potassium currents can no longer be ignored and the resting potential is given by

$$V_{rest} = \frac{G_K E_K + G_{Cl} E_{Cl} + G_F E_F}{G_K + G_{Cl} + G_F} = \frac{E_{Cl} + \frac{G_K}{G_{Cl}} E_K + \frac{G_F}{G_{Cl}} E_F}{1 + \frac{G_K}{G_{Cl}} + \frac{G_F}{G_{Cl}}}$$

Note that increasing  $G_K$  will not change the resting potential, because  $V_{rest} \propto E_K$ . Assuming that the behavior of the  $F^-$  and the  $Cl^-$  channels do not change when the  $K^+$  channel is added, the conductance ratios when the cell is perturbed will be

$$\frac{G_K}{G_{Cl}} = 4 \quad \text{and} \quad \frac{G_F}{G_{Cl}} = 1.24, \text{ as before}$$

If  $G_K$  does not change between resting and perturbed states, then  $G_K/G_{Cl} = 4 \cdot 0.11/1.24 = 0.37$  in the resting state.

**Problem 3**

The circuit for one cell is drawn below:

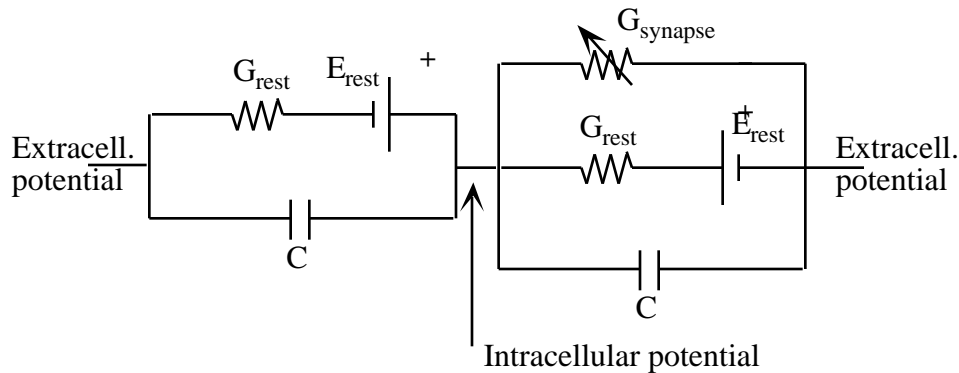

The intracellular node is marked and the nodes marked “Extracellular potential” represent the extracellular space between cells. The resting membrane is represented by a Thèvenin equivalent battery-resistor pair ( $G_{rest}, E_{rest}$ ). Note that  $E_{rest}$  is  $-60$  mV, so the actual potential of the batteries are the reverse of those drawn. No battery is shown for the synapse, because the reversal potential of this synapse is  $0$  mV. When the synapse is not activated, the system looks like a long series of oppositely-directed batteries, as below (ignoring the capacitors).

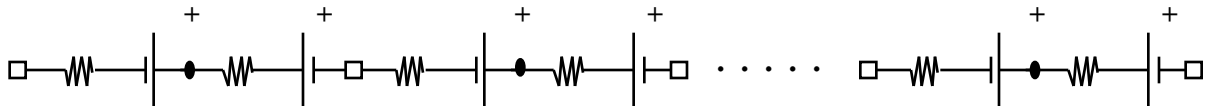

The filled circles (●) are the intracellular nodes and the unfilled squares (□) are the extracellular nodes. Clearly the potential across this whole circuit is zero. When the synapses are activated, the circuit looks like that below:

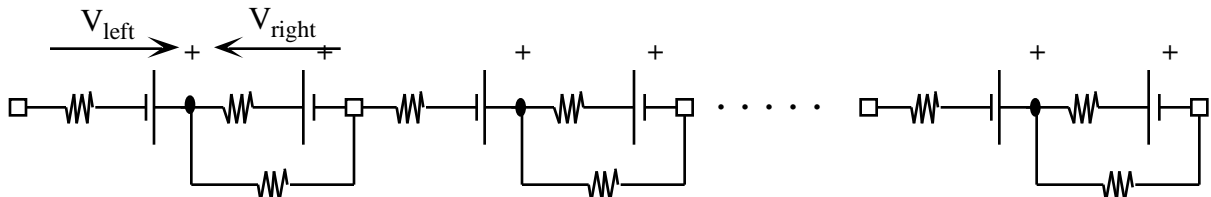

Now the potential across the left-facing membrane  $V_{left}$  is different from, and larger than, the potential across the right-facing membrane  $V_{right}$ . In the limiting case where  $G_{synapse} \gg G_{rest}$ ,  $V_{right}$  will be approximately 0 and the potential across the whole stack of cells will be the sum of the potentials across the left-facing membranes. Because  $E_{rest}$  is negative, this sum will have the polarity shown in the drawing in the problem statement. If there are  $N$  cells, this potential could be as large as  $60N$  mV.

#### Problem 4

**Part a)** The HH models for a persistent Na channel and for a delayed-rectifier K channel are given below:

$$g_K = \bar{g}_K n^4 \quad \text{and} \quad g_{PNa} = \bar{g}_{PNa} m^2$$

$$\frac{dn}{dt} = \frac{n(V) - n}{\tau_n(V)} \quad \text{and} \quad \frac{dm}{dt} = \frac{m(V) - m}{\tau_m(V)}$$

The power of  $m$  used in the literature varies and doesn't effect the answer to this problem. For example, one model considered in class used  $m$  and another used  $m^3$ ; the value of 2 used above is arbitrary.

The potassium and persistent-sodium models are identical in structure and differ only in the details of the  $x$  and  $x$  functions. However since both  $n$  and  $m$  are activation functions, they will have the same general form. That is, both  $n$  and  $m$  are monotonically increasing functions of membrane potential and  $n$  and  $m$  have a similar form. Thus the outcome of the linearization will take the same form for the persistent Na channel as for the delayed-rectifier K channel, with appropriate substitution of HH functions.

The conductance  $1/r_1$  is equal to the resting conductance of the K-channel model. By analogy, for the persistent Na channel,

$$1/r_1 = \bar{g}_{PNa} m^2(V_r) \quad (2)$$

The inductance and  $r_0$  values are

$$L_{PNa} = \frac{\tau_m(V_r)}{\left. \frac{g_{PNa}(t)}{V} \right|_{V=V_r} (V_r - E_{Na})} = \frac{\tau_m(V_r)}{2\bar{g}_{PNa} m(V_r) \left. \frac{m}{V} \right|_{V=V_r} (V_r - E_{Na})} \quad (3)$$

$$r_{0PNa} = L_{PNa} / \tau_m(V_r)$$

where the substitutions  $m$  for  $n$ ,  $\bar{g}_{PNa}$  for  $\bar{g}_K$ ,  $2m$  for  $4n^3$ ,  $m/V$  for  $n/V$ , and  $E_{Na}$  for  $E_K$  have been made.  $2m$  is substituted for  $4n^3$  because these terms come from the derivative  $\partial g(t)/\partial V$ .

**Part b)** From Eqn. 2 above, it is clear that  $r_1$  is positive. In Eqn. 3, however, all terms are positive except  $(V_r - E_{Na})$  which is negative,  $-60 - 45 = -105$  mV. Thus,  $L_{PNa}$  and  $r_{0PNa}$  are both negative. When linearized, a sodium channel's activation gating adds a negative resistance and

inductance to the membrane. Note that the equivalent term for the potassium channel,  $(V_r - E_K)$ , is positive,  $-60 - (-75) = 15$  mV.

**Part c)** The cable model, in compartmental form, for a cylinder containing persistent Na channels is shown at right for a compartment of length  $x$  (the external resistance  $r_e$  has been ignored). The batteries have been deleted, since this is a linear circuit. At D.C., the inductance  $L$  has zero impedance and disappears from the circuit. This leaves the three conductances in parallel, so that the net conductance  $g_{net} x$  of the compartment is

$$g_{net} x = (g_m + g_1 + g_0) x$$

$$(g_m + g_0) x$$

where the approximation follows from the fact that  $|r_l| \gg |r_0|$  which is the same as  $|g_l| \ll |g_0|$ , so that  $g_l$  can be ignored. The space constant is

$$\lambda = \sqrt{\frac{1/g_{net}}{r_i}} = \sqrt{\frac{1}{(g_m + g_0)r_i}}$$

Now  $g_0$  is negative, so that  $g_{net} < g_m$  and is larger than it would be in the absence of the persistent Na channel. Note that if  $g_m + g_0$  is zero,  $\lambda$  is infinite and if  $g_m + g_0$  is negative, then  $\lambda$  becomes imaginary and oscillatory solutions result.

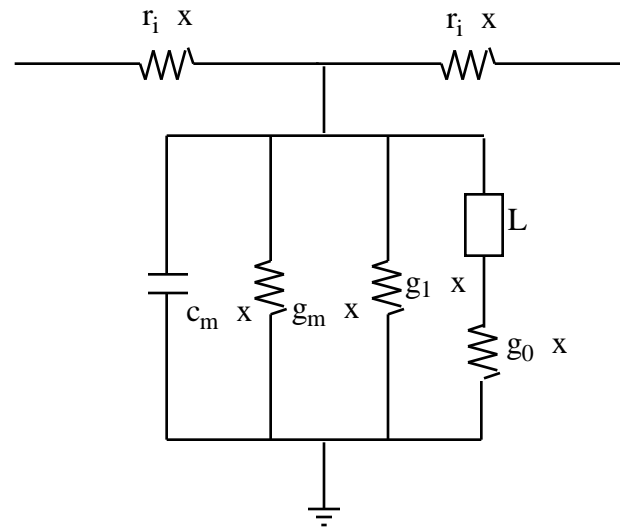

**Problem 5**

**Part a)** The equivalent cylinder theorem has three requirements:

(1) Equal electrotonic lengths along all paths. In this case:

$$L_1 + L_2 = L_1 + L_3 \quad \text{equivalent to} \quad L_2 = L_3$$

$$L_2 = \frac{l_2}{\lambda_2} = L_3 = \frac{l_3}{\lambda_3}$$

$$\frac{l_2}{\lambda_2} = \frac{l_2}{\sqrt{\frac{R_m a_2}{2R_i}}} = \frac{l_3}{\lambda_3} = \frac{l_3}{\sqrt{\frac{R_m a_3}{2R_i}}} \quad \text{equivalent to} \quad \frac{l_2}{\sqrt{a_2}} = \frac{l_3}{\sqrt{a_3}}$$

(2) The 3/2 power law holds at each branchpoint. In this case:

$$a_1^{3/2} = a_2^{3/2} + a_3^{3/2} \quad \text{which guarantees that } G_1 = G_2 + G_3$$

(3) The termination conditions are the same at every branch end. In this case:

$$\frac{Y_2}{qG_2} = \frac{Y_3}{qG_3} \quad \text{or} \quad \frac{Y_2}{\sqrt{\frac{2\pi^2}{R_m R_i} a_2^{3/2}}} = \frac{Y_3}{\sqrt{\frac{2\pi^2}{R_m R_i} a_3^{3/2}}} \quad \text{or} \quad \frac{Y_2}{a_2^{3/2}} = \frac{Y_3}{a_3^{3/2}}$$

**Part b)** The equivalent cylinder is sketched below:

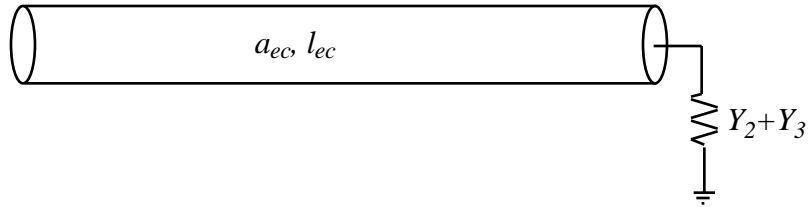

Its radius  $a_{ec}$  is the same as the radius of the original parent cylinder, i.e.  $a_{ec} = a_1 = (a_2^{3/2} + a_3^{3/2})^{2/3}$ . Its length constant  $l_{ec}$  is also the same as in the original parent cylinder, i.e.  $l_{ec} = l_1$  and its electrotonic length must be  $L_{ec} = L_1 + L_2 = L_1 + L_3$ ; as a result, its physical length can be computed as follows:

$$L_{ec} = \frac{l_{ec}}{\lambda_{ec}} = \frac{l_1}{\lambda_1} + \frac{l_2}{\lambda_2} \quad \text{so} \quad l_{ec} = \lambda_{ec} \left( \frac{l_1}{\lambda_1} + \frac{l_2}{\lambda_2} \right) = l_1 + l_2 \frac{\lambda_{ec}}{\lambda_2} = l_1 + l_2 \sqrt{\frac{a_1}{a_2}}$$

and of course this can also be written as  $l_{ec} = l_1 + l_3 \sqrt{a_1/a_3}$ . Its  $G$  value is equal to  $G_1$  and the termination admittance is  $Y_2 + Y_3$ , as given in the figure.

**Part c)** Using an equation developed in lecture, the potential in a cylinder of electrotonic length  $L$  terminated by an admittance  $Y$  and driven by a potential  $\bar{V}_0$  at  $\chi = 0$  is

$$\bar{V}(\chi) = \bar{V}_0 \frac{\cosh[q(L - \chi)] + \frac{Y}{Gq} \sinh[q(L - \chi)]}{\cosh[qL] + \frac{Y}{Gq} \sinh[qL]}$$

The diagram shows a horizontal cylinder of length  $L$ . The left end is labeled  $\chi = 0$  and has an arrow pointing into it labeled  $\bar{V}_0$ . The right end is labeled  $\chi = L$  and is connected to a vertical branch containing a resistor symbol and a ground symbol, with the admittance  $Y$  indicated next to the resistor.

The parent portion of the original tree is identical to the first  $L_1$  of the equivalent cylinder in all physical and cable parameters, as shown in part c). Thus  $q$ ,  $L$ , and  $G$  are identical for the equation above in the first  $L_1$  of the equivalent cylinder and in the parent cylinder of the original tree. The load admittance  $Y$  is also the same, as was proved in class and as given in the problem statement. Thus the potential  $\bar{V}(\chi)$  must be the same in the parent portions of the original tree and the equivalent cylinder.

**Part d)** The equation used in part c) above applies to the child cylinders of the original tree and to the child portion (electrotonic lengths  $[L_1, L_1 + L_2]$ ) of the equivalent cylinder, except that  $\bar{V}_0$  should be replaced by  $\bar{V}(L_1)$ , the potential at the branchpoint. It follows from part c) that  $\bar{V}(L_1)$  is the same in the equivalent cylinder and the original tree. Since the electrotonic lengths of the child cylinders and the child portion of the equivalent cylinder are the same, the equation above will be identical for the child cylinders and the child portion of the equivalent cylinder if the termination conditions  $Y/Gq$  are the same. One of the conditions of the equivalent cylinder theorem is that the termination conditions for the child branches are the same, i.e.  $Y_2/G_2q = Y_3/G_3q$ , so it is only necessary to

show that  $Y_2/G_{2q} = Y_3/G_{3q} = (Y_2 + Y_3)/G_{1q}$ , i.e. that the termination condition for the equivalent cylinder is the same as for the child branches. This fact was proven in lecture as follows:

$$\frac{Y_2}{G_{2q}} = \frac{Y_3}{G_{3q}} = \frac{Y_3}{G_{3q}} \frac{1+Y_2/Y_3}{1+Y_2/Y_3} = \frac{Y_3}{G_{3q}} \frac{1+Y_2/Y_3}{1+G_{2q}/G_{3q}}$$

where the last step derives from the condition of the equivalent cylinder theorem that  $Y_2/G_{2q} = Y_3/G_{3q}$  so that  $Y_2/Y_3 = G_{2q}/G_{3q}$ . Then

$$\begin{aligned} \frac{Y_2}{G_{2q}} &= \frac{Y_2 + Y_3}{G_{2q} + G_{3q}} \\ &= \frac{Y_2 + Y_3}{G_{1q}} \end{aligned}$$

as needed.